

# CHANNEL ISLANDS BEACH COMMUNITY SERVICES DISTRICT

## OPERATING & CAPITAL BUDGET

FY 2020 - 2021



# **CHANNEL ISLANDS BEACH COMMUNITY SERVICES DISTRICT**

**DRAFT**

## **FY 2020 – 2021 Operating & Capital Budgets**

MAY 2020



---

***Board of Directors:***

---

Bob Nast, *President*  
Sean Debley, *Vice President*  
Jared Bouchard, *Director*  
Kristina Brewer, *Director*  
Marcia Marcus, *Director*

---

***Budget Preparation Team:***

---

Peter Martinez, *General Manager*  
CJ Dillon, *Office Manager*  
Jesus Navarro, *Operations Manager*  
Erika Davis, *Clerk of the Board*  
Keila Wilson, *Admin Asst. II*

<b>Glossary of Terms</b>	
<b>High Level</b>	
Operating Budget	Expected future costs and forecasted income over the course of a fiscal year.
Capital Improvement Program	Short-range plan which identifies capital projects and equipment purchases, with anticipated costs associated with each project for each fiscal year.
Enterprise	A segregated account from other funds and accounts of the District with the intent that revenues generated by the enterprise will only be used to fund the operations and capital of the enterprise. District has Water, Sewer, and Solid Waste Enterprises.
Enterprise Allocation	Amount of overhead costs that is attributable to a particular enterprise fund.
Maintenance Improvement	Funds spent on District assets to maintain functionality or prolong life of said improvement.
<b>Fund Balance</b>	
Capital Reserve	Funds reserved for large anticipated expenses related to the procurement and/or construction of capital assets. Currently set at 3.5% of District asset value.
Operating Reserve	Funds reserved for unexpected shortages of cash flows to allow the District to pay obligations. Currently set at 25% of Operating Expenses, or 90 days of operations.
Rate Stabilization Reserve	Funds reserved to weather sharp unanticipated changes in District costs, to smooth rate adjustments over time, rather than cause rate spikes. Set at 10% of annual operating expenses.
Beginning Balance	Amount of funds in the account at the beginning of a new fiscal year – July 1.
Ending Balance	Amount of funds in the account at the end of a fiscal year – June 30.
<b>Accounting</b>	
Operating Revenues	Cash proceeds from providing water, sewer, or trash services.
Operating Expenses	Costs incurred from providing water, sewer, or trash services.
Net Operating Income	Operating Revenues less Operating Expenses.
Other Revenues	Proceeds generated from non-service activities.
Debt Service	Annual payments towards loans and bonds in the current year.
Debt-to-Equity Ratio	Net Operating Income divided by Debt Service. Ratio must be kept above 1.25 to maintain covenants stipulated by creditors.

<b>Glossary of Terms</b>	
<b>Reserves</b>	
Reserve Contribution	Cash set aside for transfer to one of three reserve accounts for each enterprise.
Unrestricted	Reserve funds set aside for District's operating activities without a prescribed policy minimum or specific function.
Board Restricted	Reserve funds set aside to meet the District's adopted financial policies with respect to minimum targets for Operating Reserve, Rate Stabilization Reserve, and Capital Reserve.
Outside Restricted	Reserve funds set aside to meet bond covenants as stipulated by creditors. Funds also contain customer deposits.
<b>Timeline</b>	
Adopted	Program costs approved by Board prior to the start of current fiscal year.
Actual Through	Program costs that have been incurred as of a particular date during the fiscal year.
Projected	Estimated program costs by the end of the fiscal year based current expenditures and remaining anticipated obligations.
Proposed	Requested budget amount for upcoming fiscal year.
Carryover	Unspent capital project funds from a previously approved capital year that is encumbered for use in current fiscal year for same project.
Expended	Portion of capital project funds from previous fiscal year(s) that was spent towards project costs.

## Commonly Used Abbreviations

<b>ACWA</b>	Association of California Water Agencies
<b>ACWA/JPIA</b>	ACWA Joint Powers Insurance Authority
<b>AMI</b>	Advanced Metering Infrastructure
<b>AWA</b>	Association of Water Agencies
<b>AWWA</b>	American Water Works Association
<b>CalPERS</b>	California Public Employees Retirement System
<b>CASA</b>	California Association of Sanitation Agencies
<b>CCC</b>	Cross Connection Compliance
<b>CCTV</b>	Closed Circuit Television
<b>CCWUA</b>	Channel Counties Water Utilities Agency
<b>CIBERT</b>	Channel Islands Beach Emergency Response Team
<b>CIP</b>	Capital Improvement Budget
<b>COLA</b>	Cost of Living Adjustment
<b>CSDA</b>	California Special Districts Association
<b>CWEA</b>	California Water Environment Association
<b>FY</b>	Fiscal Year
<b>I&amp;I</b>	Inflow and Infiltration (into sewer collection system)
<b>LAFCO</b>	Local Agency Formation Commission
<b>LGFA</b>	Local Government Finance Act
<b>MOU</b>	Memorandum of Understanding
<b>NASSCO</b>	National Association of Sewer Service Companies
<b>PHWA</b>	Port Hueneme Water Agency
<b>R &amp; M</b>	Repair & Maintenance
<b>SCADA</b>	Supervisory Control and Data Acquisition
<b>SDHS</b>	State Department of Health Services
<b>SWRCB</b>	State Water Resources Control Board
<b>VCEHD</b>	Ventura County Environmental Health Division
<b>VCSDA</b>	Ventura County Special Districts Association
<b>WAN</b>	Wide Area Network
<b>WPD</b>	Watershed Protection District

## ALLOCATION METHODS

The District is comprised of three enterprise funds – Water Enterprise, Sewer Enterprise, and Solid Waste Enterprise. The revenues generated by each enterprise are used to support operational activities for only that same enterprise. While several budget items are entirely attributable to a single enterprise, there are many others that are shared between more than one enterprise. To appropriately assign shared costs to each enterprise, an allocation method, or basis for splitting costs is employed. The table below shows the name of the allocation method, the percentage of costs distributed to each enterprise, and the description.

Allocation Method	Water	Sewer	Trash	Community	Description
<b>Water Only</b>	100%	0%	0%	0%	Allocated entirely to Water Enterprise.
<b>Sewer Only</b>	0%	100%	0%	0%	Allocated entirely to Sewer Enterprise.
<b>Solid Waste Only</b>	0%	0%	100%	0%	Allocated entirely to Solid Waste Enterprise.
<b>Comm Svc Only</b>	0%	0%	0%	100%	Allocated entirely to Community Service Account.
<b>Equal Distribution</b>	33%	34%	33%	0%	Split equally among Water, Sewer, and Solid Waste Enterprises.
<b>Staff Time</b>	39%	40%	19%	2%	Split based on how staff time is spent.
<b>Expense Basis</b>	36%	42%	22%	0%	Split based on ratio of operating expenses from each enterprise.
<b>Revenue Basis</b>	41%	44%	15%	0%	Split based on ratio of revenues from each enterprise.
<b>Rev. Water/Sewer</b>	49%	52%	0%	0%	Split based on ratio of revenues from only Water and Sewer.
<b>Ops Time</b>	43%	41%	14%	2%	Split based on how Operations staff time is spent.
<b>Interest Earnings</b>	35%	55%	10%	0%	Split based on interest generated by each enterprise.

Sheet No.	Account	Adopted	Actual Through	Projected	Proposed	Percent Expended	Water Enterprise		Sewer Enterprise		Solid Waste Enterprise		Community Service		Total
		FY 2019 - 2020	3/31/2020	June 2020	FY 2020 - 2021		\$	%	\$	%	\$	%	\$	%	
<b>OPERATING REVENUES</b>															
<b>Rate Revenues</b>															
1	Water Revenue	3110	2,198,000	1,628,917	2,100,000	96%	2,264,000	100%	0	0%	0	0%	0	0%	2,264,000
2	Sewer Revenue	3120	2,270,000	1,781,346	2,201,943	97%	0	0%	2,400,000	100%	0	0%	0	0%	2,400,000
3	Solid Waste Revenue	3130	731,000	569,130	749,275	103%	0	0%	0	0%	750,000	100%	0	0%	750,000
<b>Total Rate Revenues</b>			\$ 5,199,000	\$ 5,051,218	\$ 5,414,000	97%	\$ 2,264,000		\$ 2,400,000		\$ 750,000		\$ -	\$ 5,414,000	
<b>OPERATING EXPENSES</b>															
<b>Water System Expense</b>															
4	PHWA Water Contract	4210	810,000	530,772	710,000	88%	900,000	100%	0	0%	0	0%	0	0%	900,000
5	Water Sampling	4215	16,000	9,552	14,000	88%	15,000	100%	0	0%	0	0%	0	0%	15,000
6	SWRCB Annual Admin Fee	4220	14,000	13,180	14,000	100%	14,000	100%	0	0%	0	0%	0	0%	14,000
7	Annual Water Quality Report	4225	4,000	0	4,000	100%	4,000	100%	0	0%	0	0%	0	0%	4,000
8	Cross Connect Contract Charge	4230	1,800	840	1,680	93%	2,000	100%	0	0%	0	0%	0	0%	2,000
9	Water Repair & Maintenance	4235	130,000	79,326	130,000	100%	130,000	100%	0	0%	0	0%	0	0%	130,000
10	Telemetry	4240	11,000	6,600	10,000	91%	10,600	100%	0	0%	0	0%	0	0%	10,600
<b>Total Water System Expense</b>			\$ 986,800	\$ 883,680	\$ 1,075,600	90%	\$ 1,075,600		\$ -		\$ -		\$ -	\$ 1,075,600	
<b>Sewer System Expense</b>															
11	Wastewater Transportation	4260	830,000	680,106	925,000	111%	0	0%	980,000	100%	0	0%	0	0%	980,000
12	Sewer Repair & Maintenance	4265	114,000	39,700	110,000	96%	0	0%	97,000	100%	0	0%	0	0%	97,000
13	Telemetry	4270	38,000	20,760	30,000	79%	0	0%	34,000	100%	0	0%	0	0%	34,000
14	Power	4275	20,000	12,987	17,000	85%	0	0%	20,000	100%	0	0%	0	0%	20,000
<b>Total Sewer System Expense</b>			\$ 1,002,000	\$ 1,082,000	\$ 1,131,000	108%	\$ -		\$ 1,131,000		\$ -		\$ -	\$ 1,131,000	
<b>Trash Expense</b>															
15	Contract Trash Services	4285	528,000	413,044	550,730	104%	0	0%	0	0%	600,000	100%	0	0%	600,000
<b>Total Trash Expense</b>			\$ 528,000	\$ 550,730	\$ 600,000	104%	\$ -		\$ -		\$ 600,000		\$ -	\$ 600,000	
<b>Maintenance Expenses</b>															
16	Gasoline	4310	15,000	7,830	10,000	67%	6,450	43%	6,150	41%	2,100	14%	300	2%	15,000
17	Vehicle Maintenance	4320	10,000	8,825	11,000	110%	5,160	43%	4,920	41%	1,680	14%	240	2%	12,000
18	Building Security	4330	3,000	1,600	2,500	83%	990	33%	1,020	34%	990	33%	0	0%	3,000
19	Building Maintenance	4340	12,000	5,731	8,000	67%	3,960	33%	4,080	34%	3,960	33%	0	0%	12,000
20	Signs & Banners	4350	1,500	0	1,500	100%	495	33%	510	34%	495	33%	0	0%	1,500
21	Public Landscaping	4360	4,500	2,620	4,000	89%	0	0%	0	0%	0	0%	4,500	100%	4,500
22	Employee Workplace Safety	4370	5,000	1,252	5,000	100%	2,150	43%	2,050	41%	700	14%	100	2%	5,000
23	Emergency Preparedness	4380	1,500	490	700	47%	0	0%	0	0%	0	0%	1,500	100%	1,500
<b>Total Maintenance Expenses</b>			\$ 52,500	\$ 42,700	\$ 54,500	81%	\$ 19,205		\$ 18,730		\$ 9,925		\$ 6,640	\$ 54,500	



Sheet No.	Account	Adopted	Actual Through	Projected	Proposed	Percent Expended	Water Enterprise		Sewer Enterprise		Solid Waste Enterprise		Community Service		Total				
		FY 2019 - 2020	3/31/2020	June 2020	FY 2020 - 2021		\$	%	\$	%	\$	%	\$	%					
<b>Salaries &amp; Benefits</b>																			
24	Regular Salaries	4400	673,000	427,120	630,000	729,600	94%	284,544	39%	291,840	40%	138,624	19%	14,592	2%	729,600			
25	Payroll Taxes	4500	19,000	8,000	16,000	29,000	84%	11,310	39%	11,600	40%	5,510	19%	580	2%	29,000			
26	Group Insurance	4525	119,000	86,805	115,000	128,000	97%	49,920	39%	51,200	40%	24,320	19%	2,560	2%	128,000			
27	Retirement Benefits	4550	68,900	41,580	60,100	74,000	87%	28,860	39%	29,600	40%	14,060	19%	1,480	2%	74,000			
28	Uniforms	4575	3,900	3,101	4,400	4,500	113%	1,935	43%	1,845	41%	630	14%	90	2%	4,500			
29	Workers' Comp Insurance	4600	13,000	5,117	10,920	12,000	84%	4,680	39%	4,800	40%	2,280	19%	240	2%	12,000			
30	Employee Education	4650	18,000	15,647	16,000	22,000	89%	8,580	39%	8,800	40%	4,180	19%	440	2%	22,000			
<b>Total Salaries &amp; Benefits</b>		\$	914,800	\$	852,420	\$	999,100	93%	\$	389,829	\$	399,685	\$	189,604	\$	19,982	\$	999,100	
<b>Administrative Expenses</b>																			
31	Regular Board Payments	5010	9,000	4,450	7,000	9,000	78%	3,510	39%	3,600	40%	1,710	19%	180	2%	9,000			
32	Special Board Meetings	5020	2,350	400	2,000	2,000	85%	780	39%	800	40%	380	19%	40	2%	2,000			
33	Board/ Committee Expenses	5030	1,000	600	1,000	1,000	100%	390	39%	400	40%	190	19%	20	2%	1,000			
34	Board Conferences & Seminars	5040	5,000	355	1,000	5,000	20%	1,950	39%	2,000	40%	950	19%	100	2%	5,000			
35	Travel & Lodging	5050	8,500	6,488	6,488	8,500	76%	3,315	39%	3,400	40%	1,615	19%	170	2%	8,500			
36	District Dues & Memberships	5100	22,000	22,040	23,650	24,000	108%	10,262	43%	9,387	39%	4,092	17%	259	1%	24,000			
37	Office Supplies	5210	7,500	6,340	7,500	8,000	100%	2,640	33%	2,720	34%	2,640	33%	0	0%	8,000			
38	On-Line Bill Paying	5215	7,000	2,796	5,000	6,000	71%	2,460	41%	2,640	44%	900	15%	0	0%	6,000			
39	Communications	5220	16,000	12,416	15,750	17,000	98%	5,610	33%	5,780	34%	5,610	33%	0	0%	17,000			
40	Printing & Publications	5230	6,000	2,149	5,000	6,000	83%	1,980	33%	2,040	34%	1,980	33%	0	0%	6,000			
41	Postage & Shipping	5240	15,000	7,000	11,000	12,000	73%	3,960	33%	4,080	34%	3,960	33%	0	0%	12,000			
42	Miscellaneous Office Expense	5250	13,200	9,688	13,700	14,700	104%	5,975	41%	6,364	43%	2,309	16%	52	0%	14,700			
43	Office Utilities	5260	3,800	2,132	3,500	3,800	92%	1,254	33%	1,292	34%	1,254	33%	0	0%	3,800			
44	Office Equipment Maintenance	5290	8,000	5,730	9,000	9,000	113%	2,970	33%	3,060	34%	2,970	33%	0	0%	9,000			
45	Capital Replacement	5295	49,000	3,000	3,000	8,000	6%	2,640	33%	2,720	34%	2,640	33%	0	0%	8,000			
46	Insurance	5400	39,000	27,911	37,000	39,000	95%	15,990	41%	17,160	44%	5,850	15%	0	0%	39,000			
47	Legal Services	5510	60,000	20,836	40,000	60,000	67%	36,400	61%	17,600	29%	6,000	10%	0	0%	60,000			
48	Accounting Services	5520	48,000	44,115	49,000	51,000	102%	20,910	41%	22,440	44%	7,650	15%	0	0%	51,000			
49	Computer Services & Subscriptions	5530	19,000	21,549	26,000	52,000	137%	21,320	41%	22,880	44%	7,800	15%	0	0%	52,000			
50	Engineering Services	5540	60,000	32,690	75,000	75,000	125%	30,750	41%	33,000	44%	11,250	15%	0	0%	75,000			
51	Bank & Trustee Fees	5560	4,000	2,500	4,000	4,000	100%	1,640	41%	1,760	44%	600	15%	0	0%	4,000			
52	Other Professional Services	5565	10,000	24,708	30,000	30,000	300%	12,300	41%	13,200	44%	4,500	15%	0	0%	30,000			
53	Legal Notices Publication	5600	3,000	637	1,500	7,000	50%	2,310	33%	2,380	34%	2,310	33%	0	0%	7,000			
54	Public Information & Outreach	5650	14,000	5,231	8,000	14,000	57%	4,620	33%	4,760	34%	4,620	33%	0	0%	14,000			
<b>Total Administrative Expenses</b>		\$	430,350	\$	385,088	\$	466,000	89%	\$	195,936	\$	185,463	\$	83,780	\$	821	\$	466,000	
<b>TOTAL OPERATING EXPENSES</b>		\$	3,914,450	\$	-	\$	3,796,618	\$	4,326,200	\$	1,680,570	\$	1,734,878	\$	883,309	\$	27,443	\$	4,326,200
<b>NET OPERATING INCOME</b>		\$	1,284,550	\$	1,254,600	\$	1,087,800	\$	583,430	\$	665,122	\$	(133,309)	\$	(27,443)	\$	1,087,800		

Sheet No.	Account	Adopted FY 2019 - 2020	Actual Through 3/31/2020	Projected June 2020	Proposed FY 2020 - 2021	Percent Expended	Water Enterprise		Sewer Enterprise		Solid Waste Enterprise		Community Service		Total	
							\$	%	\$	%	\$	%	\$	%		
<b>OTHER REVENUES</b>																
55	Interest Earnings	6100	38,000	115,965	125,000	90,000	329%	31,500	35%	49,500	55%	9,000	10%	0	0%	90,000
56	Penalty Revenue	6200	25,000	13,916	15,000	25,000	60%	2,500	10%	2,500	10%	2,500	10%	17,500	70%	25,000
57	Secured & Unsecured Taxes	6320	66,000	46,080	65,000	66,000	98%	0	0%	0	0%	0	0%	66,000	100%	66,000
<b>TOTAL OTHER REVENUES</b>			\$ 129,000	\$ 205,000	\$ 181,000	159%	\$ 34,000		\$ 52,000		\$ 11,500		\$ 83,500		\$ 181,000	
<b>DEBT OBLIGATIONS</b>																
58	2012 Water Revenue Bonds	2805	313,000	312,834	312,834	311,000	100%	311,000	100%	0	0%	0	0%	0	0%	311,000
59	2016 Sewer Refunding Bonds	2855	191,000	146,290	186,991	220,000	98%	0	0%	220,000	100%	0	0%	0	0%	220,000
60	CSDA Loan - Smart Meter Project	2700	85,000	85,000	85,000	85,000		41,225	49%	43,775	52%	0	0%	0	0%	85,000
<b>TOTAL DEBT OBLIGATION</b>			\$ 504,000	\$ 499,825	\$ 531,000	99%	\$ 352,225		\$ 263,775		\$ -		\$ -		\$ 616,000	
<b>OTHER BUDGET ITEMS</b>																
61	Allocation of Community Service	N/A	50,000	0	0	50,000	0%	24,250	49%	25,750	52%	0	0%	(50,000)	0%	0
<b>TOTAL OTHER BUDGET ITEMS</b>			\$ 50,000	\$ -	\$ 50,000		\$ 24,250		\$ 25,750		\$ -		\$ (50,000)		\$ -	
<b>AVAILABLE FOR CAPITAL &amp; RESERVES</b>			\$ 859,550	\$ -	\$ 959,775	\$ 687,800		\$ 240,955		\$ 427,597		\$ (121,809)		\$ 106,057	\$ 652,800	
<b>RESERVE CONTRIBUTIONS</b>																
<b>Unrestricted</b>																
	Water						0		0		0		0		0	
	Sewer						0		0		0		0		0	
	Solid Waste						0		0		0		0		0	
	Community Reserves						0		0		0		106,057		106,057	
<b>Total Unrestricted Contributions</b>							\$ -		\$ -		\$ -		\$ 106,057		\$ 106,057	
<b>Board Restricted</b>																
	Water Operations Reserve						0		0		0		0		0	
	Water Rate Stabilization						22,000		0		0		0		22,000	
	Water Capital Reserve						219,000		0		0		0		219,000	
	Sewer Operations Reserve						0		0		0		0		0	
	Sewer Rate Stabilization						0		0		0		0		0	
	Sewer Capital Reserve						0		427,597		0		0		427,597	
	Solid Waste Operations Reserve						0		0		0		0		0	
	Solid Waste Rate Stabilization						0		0		(121,809)		0		(121,809)	
	Solid Waste Capital Reserve						0		0		0		0		0	
<b>Total Board Restricted Contributions</b>							\$ 241,000		\$ 427,597		\$ (121,809)		\$ -		\$ 546,788	
<b>Outside Restricted</b>																
	Water						0		0		0		0		0	
	Sewer						0		0		0		0		0	
	Solid Waste						0		0		0		0		0	
<b>Total Outside Restricted Contributions</b>							\$ -		\$ -		\$ -		\$ -		\$ -	
<b>AVAILABLE AFTER RESERVE CONTRIBUTIONS</b>							\$0		\$0		\$0		\$0		\$0	

**WATER ENTERPRISE**

**Water Revenue**

**Account Number:** 3110  
**Budget Line Item:** 1

**Account Description:**

All water sales revenues from flat meter charges and volumetric water sales from all customer classes.

**Changes for FY 2020 - 2021:**

Revenue adjustment of 3% effective July 15, 2020 per Proposition 218 notice issued in September 2016.

**Budget Backup**

**Water Revenue**

Meter Flat Rate	\$ 1,208,479	53.4%
Water Usage Charges	\$ 1,055,237	46.6%
<b>Total</b>	<b>\$ 2,263,716</b>	<b>100%</b>

**Rounded To:** 3 \$ 2,264,000

	Adopted FY 2019 - 2020	Actual Through 3/31/2020	Projected June 2020	Proposed FY 2020 - 2021
Water Revenue	\$ 2,198,000	\$ 1,628,917	\$ 2,100,000	\$ 2,264,000

**SEWER ENTERPRISE**  
**Sewer Revenue**

**Account Number:** 3120

**Budget Line Item:** 2

**Account Description:**

All sewer revenues from fixed charges and volumetric sewage usage charges from approximately 2236 sewer connections.

**Changes for FY 2020 - 2021:**

Revenue adjustment of 6% effective July 15, 2020 per Proposition 218 notice issued in September 2016. Payment from County Watershed Protection District (WPD) for diverting stormwater into District's sewage collection system to improve coastal water quality is anticipated in FY 2022. No additional revenue in FY 2021.

**Budget Backup**

**Sewer Revenue**

Fixed Charges	\$	716,210
Sewer Usage Charges	\$	734,605
Sewer Transportation-City of Oxnard	\$	946,000
San Nicholas Stormwater Diversion - County WPD	\$	-
<b>Total</b>	<b>\$</b>	<b>2,396,815</b>

**Rounded To:** \$ 2,400,000

	Adopted FY 2019 - 2020	Actual Through 3/31/2020	Projected June 2020	Proposed FY 2020 - 2021
Sewer Revenue	\$ 2,270,000	\$ 1,781,346	\$ 2,201,943	\$ 2,400,000

## TRASH ENTERPRISE Solid Waste Revenue

**Account Number:** 3130  
**Budget Line Item:** 3

**Account Description:**  
All trash revenues from flat trash service charges, walk-in service, and large bin rental.

**Changes for FY 2020 - 2021:**  
Revenue adjustment of 2.5% effective July 15, 2020 per Proposition 218 notice issued in September 2016. Will require approximately \$18,000 from reserves to balance Enterprise for FY 2020-2021.

### Budget Backup

Solid Waste Revenue	
EJ Harrison Contract Costs	\$ 750,000
<b>Total</b>	<b>\$ 750,000</b>

Rounded To: \$ 750,000

3

	Adopted FY 2019 - 2020	Actual Through 3/31/2020	Projected June 2020	Proposed FY 2020 - 2021
Solid Waste Revenue	\$ 731,000	\$ 569,130	\$ 749,275	\$ 750,000

**WATER ENTERPRISE**  
**PHWA Water Contract**

**Account Number:** 4210

**Budget Line Item:** 4

**Account Description:**

Water supply costs from the Port Hueneme Water Agency.

**Changes for FY 2020 - 2021:**

Anticipated increase in PHWA water supply costs.

**Budget Backup**

PHWA Water Contract	Quantity	Rate	Total	Allocation
Monthly Fixed Costs	12	\$ 40,000	\$ 480,000	Water Only
Variable Water Purchase Costs	460	\$ 900	\$ 414,000	Water Only
<b>Total</b>			<b>\$ 894,000</b>	

**Rounded To:** \$ 900,000

4

	Adopted FY 2019 - 2020	Actual Through 3/31/2020	Projected June 2020	Proposed FY 2020 - 2021
PHWA Water Contract	\$ 810,000	\$ 530,772	\$ 710,000	\$ 900,000

Enterprise Allocation		Calculated	Rounded
Water	100%	\$ 894,000	\$ 900,000
Sewer	0%	\$ -	\$ -
Trash	0%	\$ -	\$ -
Community	0%	\$ -	\$ -
<b>Total</b>	<b>100%</b>	<b>\$ 894,000</b>	<b>\$ 900,000</b>

## WATER ENTERPRISE *Water Sampling*

**Account Number:** 4215

**Budget Line Item:** 5

**Account Description:**

Weekly bacteriological sampling and analyses required by the State Water Resources Control Board (SWRCB). Results are submitted to SWRCB via the District's monthly report.

**Changes for FY 2020 - 2021:**

None

### Budget Backup

Water Sampling	Quantity	Rate	Total	Allocation
Weekly Sampling Costs	52	\$ 150	\$ 7,800	<i>Water Only</i>
Lead and Copper Testing	0	\$ 1,200	\$ -	<i>Water Only</i>
Disinfection Monitoring	1	\$ 2,500	\$ 2,500	<i>Water Only</i>
Miscellaneous Testing	1	\$ 2,100	\$ 2,100	<i>Water Only</i>
Hardness, Nitrate Monitoring	1	\$ 2,100	\$ 2,100	<i>Water Only</i>
<b>Total</b>			<b>\$ 14,500</b>	

**Rounded To: \$ 15,000**

3

	Adopted FY 2019 - 2020	Actual Through 3/31/2020	Projected June 2020	Proposed FY 2020 - 2021
Water Sampling	\$ 16,000	\$ 9,552	\$ 14,000	\$ 15,000

Enterprise Allocation		Calculated	Rounded
Water	100%	\$ 14,500	\$ 15,000
Sewer	0%	\$ -	\$ -
Trash	0%	\$ -	\$ -
Community	0%	\$ -	\$ -
<b>Total</b>	<b>100%</b>	<b>\$ 14,500</b>	<b>\$ 15,000</b>

## WATER ENTERPRISE SWRCB Annual Admin Fee

**Account Number:** 4220

**Budget Line Item:** 6

**Account Description:**

Regulatory fees due to the State Water Resources Control Board, the State Regulatory Agency overseeing community water systems.

**Changes for FY 2020 - 2021:**

None

### Budget Backup

SWRCB Annual Admin Fee	Total	Allocation
Base Fee	\$ 10,000	<i>Water Only</i>
Inspections & Compliance Tracking	\$ 4,000	<i>Water Only</i>
<b>Total</b>	<b>\$ 14,000</b>	

**Rounded To: \$ 14,000**

	Adopted FY 2019 - 2020	Actual Through 3/31/2020	Projected June 2020	Proposed FY 2020 - 2021
SWRCB Annual Admin Fee	\$ 14,000	\$ 13,180	\$ 14,000	\$ 14,000

Enterprise Allocation		Calculated	Rounded
Water	100%	\$ 14,000	\$ 14,000
Sewer	0%	\$ -	\$ -
Trash	0%	\$ -	\$ -
Community	0%	\$ -	\$ -
<b>Total</b>	<b>100%</b>	<b>\$ 14,000</b>	<b>\$ 14,000</b>



## WATER ENTERPRISE Annual Water Quality Report

**Account Number:** 4225  
**Budget Line Item:** 7

**Account Description:**  
Consumer Confidence Report to District Customers as mandated by the State Water Resources Control Board requirements.

**Changes for FY 2020 - 2021:**  
None

### Budget Backup

Annual Water Quality Report	Total	Allocation
Design, Print, and Mailing Costs	\$ 4,000	<i>Water Only</i>
<b>Total</b>	<b>\$ 4,000</b>	

**Rounded To:** \$ 4,000  
2

	Adopted FY 2019 - 2020	Actual Through 3/31/2020	Projected June 2020	Proposed FY 2020 - 2021
Annual Water Quality Report	\$ 4,000	\$ -	\$ 4,000	\$ 4,000

Enterprise Allocation	Calculated	Rounded
Water	100% \$ 4,000	\$ 4,000
Sewer	0% \$ -	\$ -
Trash	0% \$ -	\$ -
Community	0% \$ -	\$ -
<b>Total</b>	<b>100% \$ 4,000</b>	<b>\$ 4,000</b>

## WATER ENTERPRISE Cross Connect Contract Charge

**Account Number:** 4230  
**Budget Line Item:** 8

**Account Description:**

Cross Connection Control contract, with the County of Ventura, Environmental Health Department (VCEHD). Required monitoring of backflow devices in the District to insure against cross connections failures between potable and non-potable water systems in the District. Enforcement of CCC compliance remains with the District, however testing and repairs are done by private certified firms.

**Changes for FY 2020 - 2021:**

Increase of 19% based on VCEHD anticipated increases in FY 2020-21.

**Budget Backup**

Cross Connect Contract Charge	Quantity	Rate	Total	Allocation
Quarterly Testing	4	\$ 450	\$ 2,000	<i>Water Only</i>
<b>Total</b>			<b>\$ 2,000</b>	

**Rounded To:** \$ 2,000

2

	Adopted FY 2019 - 2020	Actual Through 3/31/2020	Projected June 2020	Proposed FY 2020 - 2021
Cross Connect Contract Charge	\$ 1,800	\$ 840	\$ 1,680	\$ 2,000

Enterprise Allocation		Calculated	Rounded
Water	100%	\$ 2,000	\$ 2,000
Sewer	0%	\$ -	\$ -
Trash	0%	\$ -	\$ -
Community	0%	\$ -	\$ -
<b>Total</b>	<b>100%</b>	<b>\$ 2,000</b>	<b>\$ 2,000</b>

## WATER ENTERPRISE Water Repair & Maintenance

**Account Number:** 4235  
**Budget Line Item:** 9

**Account Description:**  
Costs for routine repairs to water distribution system for both services and materials.

**Changes for FY 2020 - 2021:**

None

**Budget Backup**

Water Repair & Maintenance	Total	Allocation
Water Meters	\$ 2,000	Water Only
Water Meter Boxes	\$ 1,000	Water Only
Water Meter Lids	\$ 500	Water Only
Copper Tubing	\$ 3,000	Water Only
Valves	\$ 11,000	Water Only
Couplings & Adapters/Dresser couplings	\$ 4,400	Water Only
Saddles	\$ 1,800	Water Only
Repair clamps	\$ 2,000	Water Only
Tools	\$ 750	Water Only
Pipe	\$ 3,000	Water Only
Traffic plates	\$ 1,500	Water Only
No Dez	\$ 35,000	Water Only
On-Call Emergency Repair	\$ 55,000	Water Only
Backflow Testing	\$ 1,000	Water Only
Concrete	\$ 4,000	Water Only
Ashphalt	\$ 4,000	Water Only
<b>Total</b>	<b>\$ 129,950</b>	

**Rounded To: \$ 130,000**

	Adopted FY 2019 - 2020	Actual Through 3/31/2020	Projected June 2020	Proposed FY 2020 - 2021
Water Repair & Maintenance	\$ 130,000	\$ 79,326	\$ 130,000	\$ 130,000

Enterprise Allocation		Calculated	Rounded
Water	100%	\$ 129,950	\$ 130,000
Sewer	0%	\$ -	\$ -
Trash	0%	\$ -	\$ -
Community	0%	\$ -	\$ -
<b>Total</b>	<b>100%</b>	<b>\$ 129,950</b>	<b>\$ 130,000</b>

## WATER ENTERPRISE *Telemetry*

**Account Number:** 4240  
**Budget Line Item:** 10

**Account Description:**

Costs for transmitting water consumption data from smart water meters to cloud server through Advanced Metering Infrastructure. Program costs only include half of annual costs. Remaining half is funded by Sewer Enterprise.

**Changes for FY 2020 - 2021:**

None

**Budget Backup**

Telemetry	Quantity	Rate	Total	Allocation
Monthly Data Costs	12	\$ 880	\$ 10,560	<i>Water Only</i>
<b>Total</b>			<b>\$ 10,560</b>	

**Rounded To: \$ 10,600**

2

	Adopted FY 2019 - 2020	Actual Through 3/31/2020	Projected June 2020	Proposed FY 2020 - 2021
Telemetry	\$ 11,000	\$ 6,600	\$ 10,000	\$ 10,600

Enterprise Allocation		Calculated	Rounded
Water	100%	\$ 10,560	\$ 10,600
Sewer	0%	\$ -	\$ -
Trash	0%	\$ -	\$ -
Community	0%	\$ -	\$ -
<b>Total</b>	<b>100%</b>	<b>\$ 10,560</b>	<b>\$ 10,600</b>

## SEWER ENTERPRISE *Wastewater Transportation*

**Account Number:** 4260  
**Budget Line Item:** 11

**Account Description:**

Payments to the City of Oxnard to transport, treat and dispose of the District's sewage at the Oxnard Regional Wastewater Treatment Plant. The rate shown for each bill component is adjusted on January 1 of each year. The rate shown is an average of the two calendar year rates within the fiscal year.

**Changes for FY 2020 - 2021:**

Additional costs to treat stormwater from San Nicholas Diversion offset by Sewer Revenues.

**Budget Backup**

Wastewater Transportation	Quantity	Rate (Average)	Total	Allocation
Flow (mg)	332.76	\$ 1,898	\$ 631,578	<i>Sewer Only</i>
BOD (lbs)	634.8	\$ 215	\$ 136,482	<i>Sewer Only</i>
TSS (lbs)	610.44	\$ 315	\$ 192,289	<i>Sewer Only</i>
O&M Share of Oxnard LS #29			\$ 17,851	<i>Sewer Only</i>
San Nicholas Diversion Treatment			\$ -	<i>Sewer Only</i>
<b>Total</b>			<b>\$ 978,200</b>	

**Rounded To: \$ 980,000**

	Adopted FY 2019 - 2020	Actual Through 3/31/2020	Projected June 2020	Proposed FY 2020 - 2021
Wastewater Transportation	\$ 830,000	\$ 680,106	\$ 925,000	\$ <b>980,000</b>

Enterprise Allocation		Calculated	Rounded
Water	0%	\$ -	\$ -
Sewer	100%	\$ 978,200	\$ 980,000
Trash	0%	\$ -	\$ -
Community	0%	\$ -	\$ -
<b>Total</b>	<b>100%</b>	<b>\$ 978,200</b>	<b>\$ 980,000</b>

## SEWER ENTERPRISE Sewer Repair & Maintenance

**Account Number:** 4265

**Budget Line Item:** 12

**Account Description:**

Costs for routine repairs to sewage collection system for both services and materials.

**Changes for FY 2020 - 2021:**

Reduction in line item due to system upgrades.

### Budget Backup

Sewer Repair & Maintenance	Total	Allocation
Safety Equipment & Apparatuses	\$ 17,020	<i>Sewer Only</i>
Plugs	\$ 1,100	<i>Sewer Only</i>
Small generator	\$ 1,200	<i>Sewer Only</i>
Tools for trucks	\$ 1,500	<i>Sewer Only</i>
Saw Blades	\$ 1,000	<i>Sewer Only</i>
Manhole ring and covers	\$ 4,200	<i>Sewer Only</i>
Saw Blades	\$ 500	<i>Sewer Only</i>
NASSCO Training	\$ 3,600	<i>Sewer Only</i>
3" Trash pump	\$ 2,000	<i>Sewer Only</i>
Manhole opening tools	\$ 600	<i>Sewer Only</i>
Wastewater Electrical and Instrumentation	\$ 5,000	<i>Sewer Only</i>
Emergency Repairs	\$ 10,500	<i>Sewer Only</i>
Gravity Line Cleaning	\$ 20,000	<i>Sewer Only</i>
Wetwell & Hot Spot Cleaning	\$ 28,000	<i>Sewer Only</i>
<b>Total</b>	<b>\$ 96,220</b>	

**Rounded To: \$ 97,000**

	Adopted FY 2019 - 2020	Actual Through 3/31/2020	Projected June 2020	Proposed FY 2020 - 2021
Sewer Repair & Maintenance	\$ 114,000	\$ 39,700	\$ 110,000	\$ 97,000

Enterprise Allocation		Calculated	Rounded
Water	0%	\$ -	\$ -
Sewer	100%	\$ 76,220	\$ 97,000
Trash	0%	\$ -	\$ -
Community	0%	\$ -	\$ -
<b>Total</b>	<b>100%</b>	<b>\$ 76,220</b>	<b>\$ 97,000</b>

## SEWER ENTERPRISE *Telemetry*

**Account Number:** 4270  
**Budget Line Item:** 13

**Account Description:**

Costs for communication systems within sewer lift stations, smart meter data transmission, and smart cover satellite communication.

**Changes for FY 2020 - 2021:**

None

### Budget Backup

Telemetry	Months	Rate	Total	Allocation
XiO SCADA Service	12	\$ 900	\$ 10,800	<i>Sewer Only</i>
Smart Cover Service	12	\$ 650	\$ 7,800	<i>Sewer Only</i>
Smart Meter Telemetry	12	\$ 880	\$ 10,560	<i>Sewer Only</i>
Overages			\$ 4,000	<i>Sewer Only</i>
<b>Total</b>			<b>\$ 33,160</b>	

**Rounded To: \$ 34,000**

	Adopted FY 2019 - 2020	Actual Through 3/31/2020	Projected June 2020	Proposed FY 2020 - 2021
Telemetry	\$ 38,000	\$ 20,760	\$ 30,000	<b>\$ 34,000</b>

Enterprise Allocation		Calculated	Rounded
Water	0%	\$ -	\$ -
Sewer	100%	\$ 33,160	\$ 34,000
Trash	0%	\$ -	\$ -
Community	0%	\$ -	\$ -
<b>Total</b>	<b>100%</b>	<b>\$ 33,160</b>	<b>\$ 34,000</b>

## SEWER ENTERPRISE *Power*

**Account Number:** 4275  
**Budget Line Item:** 14

**Account Description:**  
Payments for electricity serving wastewater lift stations.

**Changes for FY 2020 - 2021:**  
None

### Budget Backup

Power	Quantity	Rate	Total	Allocation
Monthly Electrical Costs	12	\$ 1,600	\$ 19,200	<i>Sewer Only</i>
<b>Total</b>			<b>\$ 19,200</b>	

**Rounded To:** \$ 20,000

3

	Adopted FY 2019 - 2020	Actual Through 3/31/2020	Projected June 2020	Proposed FY 2020 - 2021
Power	\$ 20,000	\$ 12,987	\$ 17,000	\$ 20,000

Enterprise Allocation		Calculated	Rounded
Water	0%	\$ -	\$ -
Sewer	100%	\$ 19,200	\$ 20,000
Trash	0%	\$ -	\$ -
Community	0%	\$ -	\$ -
<b>Total</b>	<b>100%</b>	<b>\$ 19,200</b>	<b>\$ 20,000</b>



## TRASH ENTERPRISE Contract Trash Services

**Account Number:** 4285  
**Budget Line Item:** 15

**Account Description:**

Contract trash collection and recycling service payments to EJ Harrion & Sons pursuant to Trash and Disposal Agreement dated Jan. 9, 2018. Also provides for one community clean up event per year and HHW pickup.

**Changes for FY 2020 - 2021:**

Contractual increase of 3% planned for FY 2020-2021. Enterprise is currently underfunded by approximately \$25,000. Rate parity will be addressed in future Prop 218 notice.

**Budget Backup**

Contract Trash Services	Quantity	Rate	Total	Allocation
Monthly Contract Costs	12	\$ 50,000	\$ 600,000	<i>Solid Waste Only</i>
<b>Total</b>			<b>\$ 600,000</b>	

**Rounded To: \$ 600,000**

	Adopted FY 2019 - 2020	Actual Through 3/31/2020	Projected June 2020	Proposed FY 2020 - 2021
Contract Trash Services	\$ 528,000	\$ 413,044	\$ 550,730	\$ 600,000

Enterprise Allocation		Calculated	Rounded
Water	0%	\$ -	\$ -
Sewer	0%	\$ -	\$ -
Trash	100%	\$ 600,000	\$ 600,000
Community	0%	\$ -	\$ -
<b>Total</b>	<b>100%</b>	<b>\$ 600,000</b>	<b>\$ 600,000</b>

## GENERAL Gasoline

**Account Number:** 4310  
**Budget Line Item:** 16

**Account Description:**

Gasoline purchases required to support the daily operation of the District's fleet of four vehicles and backhoe in support of the water, sewer, trash utilities and non-core utility community service programs.

**Changes for FY 2020 - 2021:**

No changes from previous fiscal year.

### Budget Backup

Gasoline	Total	Allocation
Fuel Costs	\$ 15,000	<i>Ops Time</i>
<b>Total</b>	<b>\$ 15,000</b>	

**Rounded To: \$ 15,000**

	Adopted FY 2019 - 2020	Actual Through 3/31/2020	Projected June 2020	Proposed FY 2020 - 2021
Gasoline	\$ 15,000	\$ 7,830	\$ 10,000	\$ 15,000

Enterprise Allocation		Calculated	Rounded
Water	43%	\$ 6,450	\$ 6,450
Sewer	41%	\$ 6,150	\$ 6,150
Trash	14%	\$ 2,100	\$ 2,100
Community	2%	\$ 300	\$ 300
<b>Total</b>	<b>100%</b>	<b>\$ 15,000</b>	<b>\$ 15,000</b>

## GENERAL Vehicle Maintenance

**Account Number:** 4320  
**Budget Line Item:** 17

**Account Description:**

Vehicle maintenance expenses required to support the daily operation of the District's fleet of three vehicles in support of the water, sewer, trash utilities and non-core utility community service programs.

**Changes for FY 2020 - 2021:**

Additional funds are needed to extend life of vehicles beyond historical replacement schedule, while staff determines best available option for future fleet needs.

### Budget Backup

Vehicle Maintenance	Total	Allocation
Vehicle Repair Costs	\$ 12,000	<i>Ops Time</i>
<b>Total</b>	<b>\$ 12,000</b>	

**Rounded To: \$ 12,000**

	Adopted FY 2019 - 2020	Actual Through 3/31/2020	Projected June 2020	Proposed FY 2020 - 2021
Vehicle Maintenance	\$ 10,000	\$ 8,825	\$ 11,000	\$ 12,000

Enterprise Allocation		Calculated	Rounded
Water	43%	\$ 5,160	\$ 5,160
Sewer	41%	\$ 4,920	\$ 4,920
Trash	14%	\$ 1,680	\$ 1,680
Community	2%	\$ 240	\$ 240
<b>Total</b>	<b>100%</b>	<b>\$ 12,000</b>	<b>\$ 12,000</b>

## GENERAL Building Security

**Account Number:** 4330  
**Budget Line Item:** 18

**Account Description:**  
 Subscription, service, and maintenance costs related to building alarms and camera systems.

**Changes for FY 2020 - 2021:**  
 None

### Budget Backup

Building Security	Quantity	Rate	Total	Allocation
Bay Alarm Monthly Services	12	\$ 250	\$ 3,000	<i>Equal Distribution</i>
<b>Total</b>			<b>\$ 3,000</b>	

**Rounded To:** \$ 3,000

2

	Adopted FY 2019 - 2020	Actual Through 3/31/2020	Projected June 2020	Proposed FY 2020 - 2021
Building Security	\$ 3,000	\$ 1,600	\$ 2,500	\$ 3,000

Enterprise Allocation		Calculated	Rounded
Water	33%	\$ 990	\$ 990
Sewer	34%	\$ 1,020	\$ 1,020
Trash	33%	\$ 990	\$ 990
Community	0%	\$ -	\$ -
<b>Total</b>	<b>100%</b>	<b>\$ 3,000</b>	<b>\$ 3,000</b>

## GENERAL Building Maintenance

**Account Number:** 4340  
**Budget Line Item:** 19

**Account Description:**

Maintenance and supply expenses incurred by planned and unplanned repairs and improvements to the District's buildings, small equipment, storage containers and areas.

**Changes for FY 2020 - 2021:**

None

### Budget Backup

Building Maintenance	Total	Allocation
Fire Extinguisher Recharge	\$ 650	<i>Equal Distribution</i>
Electrical & Plumbing Repair	\$ 3,500	<i>Equal Distribution</i>
Carpet Cleaning	\$ 1,200	<i>Equal Distribution</i>
Fumigation	\$ 2,500	<i>Equal Distribution</i>
Front Office Flooring	\$ 500	<i>Equal Distribution</i>
Janitorial Service	\$ 3,500	<i>Equal Distribution</i>
<b>Total</b>	<b>\$ 11,850</b>	

**Rounded To:** \$ 12,000

	Adopted FY 2019 - 2020	Actual Through 3/31/2020	Projected June 2020	Proposed FY 2020 - 2021
Building Maintenance	\$ 12,000	\$ 5,731	\$ 8,000	\$ 12,000

Enterprise Allocation		Calculated	Rounded
Water	33%	\$ 3,911	\$ 3,960
Sewer	34%	\$ 4,029	\$ 4,080
Trash	33%	\$ 3,911	\$ 3,960
Community	0%	\$ -	\$ -
<b>Total</b>	<b>100%</b>	<b>\$ 11,850</b>	<b>\$ 12,000</b>

## GENERAL Signs & Banners

**Account Number:** 4350  
**Budget Line Item:** 20

**Account Description:**

Annual maintenance and/or replacement of signs and banners used by the District to inform the beach community about building uses, utility services, special programs, and non-core community services, Community Clean Up Day.

**Changes for FY 2020 - 2021:**

None

### Budget Backup

Signs & Banners	Total	Allocation
Signs & Banner Expense	\$ 1,500	<i>Equal Distribution</i>
<b>Total</b>	<b>\$ 1,500</b>	

**Rounded To:** \$ 1,500

2

	Adopted FY 2019 - 2020	Actual Through 3/31/2020	Projected June 2020	Proposed FY 2020 - 2021
Signs & Banners	\$ 1,500	\$ -	\$ 1,500	\$ 1,500

Enterprise Allocation		Calculated	Rounded
Water	33%	\$ 495	\$ 495
Sewer	34%	\$ 510	\$ 510
Trash	33%	\$ 495	\$ 495
Community	0%	\$ -	\$ -
<b>Total</b>	<b>100%</b>	<b>\$ 1,500</b>	<b>\$ 1,500</b>

**COMMUNITY SERVICE**  
***Public Landscaping***

**Account Number:** 4360  
**Budget Line Item:** 21

**Account Description:**

Annual maintenance and/or repair of existing public landscape projects at the Wanda M. Pirkle Community Park and District Office.

**Changes for FY 2020 - 2021:**

Palm tree trimming Pirkle Park

**Budget Backup**

<b>Public Landscaping</b>	Total	Allocation
Pirkle Park Maintenance	\$ 1,500	<i>Comm Svc Only</i>
Auxiliary Yard Maintenance	\$ 1,200	<i>Comm Svc Only</i>
District Yard Maintenance	\$ 1,800	<i>Comm Svc Only</i>
<b>Total</b>	<b>\$ 4,500</b>	

**Rounded To: \$ 4,500**

2

	Adopted FY 2019 - 2020	Actual Through 3/31/2020	Projected June 2020	Proposed FY 2020 - 2021
Public Landscaping	\$ 4,500	\$ 2,620	\$ 4,000	\$ 4,500

<b>Enterprise Allocation</b>		<b>Calculated</b>	<b>Rounded</b>
Water	0%	\$ -	\$ -
Sewer	0%	\$ -	\$ -
Trash	0%	\$ -	\$ -
Community	100%	\$ 3,300	\$ 4,500
<b>Total</b>	<b>100%</b>	<b>\$ 3,300</b>	<b>\$ 4,500</b>

## GENERAL Employee Workplace Safety

**Account Number:** 4370  
**Budget Line Item:** 22

**Account Description:**

Safety supplies and equipment for District personnel (not associated with a specific Enterprise fund), including, but not limited to, steel toe boots for operations department, sun screen & gas protectors.

**Changes for FY 2020 - 2021:**

None

### Budget Backup

Employee Workplace Safety	Total	Allocation
Safety Equipment	\$ 5,000	<i>Ops Time</i>
<b>Total</b>	<b>\$ 5,000</b>	

**Rounded To:** \$ 5,000

2

	Adopted FY 2019 - 2020	Actual Through 3/31/2020	Projected June 2020	Proposed FY 2020 - 2021
Employee Workplace Safety	\$ 5,000	\$ 1,252	\$ 5,000	\$ 5,000

Enterprise Allocation		Calculated	Rounded
Water	43%	\$ 2,150	\$ 2,150
Sewer	41%	\$ 2,050	\$ 2,050
Trash	14%	\$ 700	\$ 700
Community	2%	\$ 100	\$ 100
<b>Total</b>	<b>100%</b>	<b>\$ 5,000</b>	<b>\$ 5,000</b>



## COMMUNITY SERVICE *Emergency Preparedness*

**Account Number:** 4380  
**Budget Line Item:** 23

**Account Description:**

Expenditures required to support the planning, development, training and equipment of the Channel Islands Beach Community Services District Emergency Response Team (CIBERT) and coordinate the team's activities with the Ventura County Sheriff's Dept. Office.

**Changes for FY 2020 - 2021:**

**Budget Backup**

Emergency Preparedness	Total	Allocation
CERT Supplies	\$ 1,500	<i>Comm Svc Only</i>
<b>Total</b>	<b>\$ 1,500</b>	

Rounded To: \$ 1,500

2

	Adopted FY 2019 - 2020	Actual Through 3/31/2020	Projected June 2020	Proposed FY 2020 - 2021
Emergency Preparedness	\$ 1,500	\$ 490	\$ 700	\$ 1,500

Enterprise Allocation		Calculated	Rounded
Water	0%	\$ -	\$ -
Sewer	0%	\$ -	\$ -
Trash	0%	\$ -	\$ -
Community	100%	\$ 1,500	\$ 1,500
<b>Total</b>	<b>100%</b>	<b>\$ 1,500</b>	<b>\$ 1,500</b>

## GENERAL Regular Salaries

**Account Number:** 4400  
**Budget Line Item:** 24

**Account Description:**

Regular wage and salary compensation payments for the District's 8 employees: General Manager, Operations Manager, Office Manager, 2 Customer Service Reps and 3 Water/Wastewater workers.

**Changes for FY 2020 - 2021:**

Budget amount for FY 2020-2021 includes estimated COLA of 3%.

### Budget Backup

Regular Salaries	Total	Allocation
Staff Salaries	\$ 729,600	<i>Staff Time</i>
<b>Total</b>	<b>\$ 729,600</b>	

**Rounded To: \$ 729,600**

	Adopted FY 2019 - 2020	Actual Through 3/31/2020	Projected June 2020	Proposed FY 2020 - 2021
Regular Salaries	\$ 673,000	\$ 427,120	\$ 630,000	\$ 729,600

Enterprise Allocation		Calculated	Rounded
Water	39%	\$ 284,544	\$ 284,544
Sewer	40%	\$ 291,840	\$ 291,840
Trash	19%	\$ 138,624	\$ 138,624
Community	2%	\$ 14,592	\$ 14,592
<b>Total</b>	<b>100%</b>	<b>\$ 729,600</b>	<b>\$ 729,600</b>

## GENERAL Payroll Taxes

**Account Number:** 4500  
**Budget Line Item:** 25

**Account Description:**  
 Employer taxes on personnel and Board wages.

**Changes for FY 2020 - 2021:**

### Budget Backup

Payroll Taxes	Total	Allocation
Payroll Taxes	\$ 28,455	Staff Time
<b>Total</b>	<b>\$ 28,455</b>	

**Rounded To:** \$ 29,000

3

	Adopted FY 2019 - 2020	Actual Through 3/31/2020	Projected June 2020	Proposed FY 2020 - 2021
Payroll Taxes	\$ 19,000	\$ 8,000	\$ 16,000	\$ 29,000

Enterprise Allocation		Calculated	Rounded
Water	39%	\$ 11,097	\$ 11,310
Sewer	40%	\$ 11,382	\$ 11,600
Trash	19%	\$ 5,406	\$ 5,510
Community	2%	\$ 569	\$ 580
<b>Total</b>	<b>100%</b>	<b>\$ 28,455</b>	<b>\$ 29,000</b>

## GENERAL Group Insurance

**Account Number:** 4525  
**Budget Line Item:** 26

**Account Description:**

Medical Insurance provided by CalPERS. Dental, Vision and Life Insurance provided by ACWA/JPIA.

**Changes for FY 2020 - 2021:**

Anticipated 12% increase

### Budget Backup

Group Insurance	Total	Allocation
Insurance Premiums	\$ 128,000	<i>Staff Time</i>
<b>Total</b>	<b>\$ 128,000</b>	

**Rounded To: \$ 128,000**

3

	Adopted FY 2019 - 2020	Actual Through 3/31/2020	Projected June 2020	Proposed FY 2020 - 2021
Group Insurance	\$ 119,000	\$ 86,805	\$ 115,000	\$ 128,000

Enterprise Allocation		Calculated	Rounded
Water	39%	\$ 49,920	\$ 49,920
Sewer	40%	\$ 51,200	\$ 51,200
Trash	19%	\$ 24,320	\$ 24,320
Community	2%	\$ 2,560	\$ 2,560
<b>Total</b>	<b>100%</b>	<b>\$ 128,000</b>	<b>\$ 128,000</b>

**GENERAL**  
**Retirement Benefits**

**Account Number:** 4550  
**Budget Line Item:** 27

**Account Description:**

Upon enrollment in CalPERS (May 5, 2018), 6.85% of employee wages go towards Employer share of CalPERS formula. 3.47% are contributed toward employee 457 plans. Calculated by base salary rate of \$739,100

**Changes for FY 2020 - 2021:**

**Budget Backup**

Retirement Benefits	Total	Allocation
457 Deferred Compensation Employer Share	\$ 24,020	Staff Time
CalPERS Employer Contribution	\$ 49,900	Staff Time
<b>Total</b>	<b>\$ 73,920</b>	

**Rounded To: \$ 74,000**

2

	Adopted FY 2019 - 2020	Actual Through 3/31/2020	Projected June 2020	Proposed FY 2020 - 2021
Retirement Benefits	\$ 68,900	\$ 41,580	\$ 60,100	\$ 74,000

Enterprise Allocation		Calculated	Rounded
Water	39%	\$ 28,829	\$ 28,860
Sewer	40%	\$ 29,568	\$ 29,600
Trash	19%	\$ 14,045	\$ 14,060
Community	2%	\$ 1,478	\$ 1,480
<b>Total</b>	<b>100%</b>	<b>\$ 73,920</b>	<b>\$ 74,000</b>

## GENERAL Uniforms

**Account Number:** 4575  
**Budget Line Item:** 28

**Account Description:**  
 Weekly uniform cleaning and laundry expenses for District staff uniforms and towel service.

**Changes for FY 2020 - 2021:**  
 None

### Budget Backup

Uniforms	Total	Allocation
Cleaning Costs	\$ 2,220	<i>Ops Time</i>
Uniform Replacement	\$ 2,100	<i>Ops Time</i>
<b>Total</b>	<b>\$ 4,320</b>	

**Rounded To:** \$ 4,400  
 2

	Adopted FY 2019 - 2020	Actual Through 3/31/2020	Projected June 2020	Proposed FY 2020 - 2021
Uniforms	\$ 3,900	\$ 3,101	\$ 4,400	\$ 4,500

Enterprise Allocation		Calculated	Rounded
Water	43%	\$ 1,858	\$ 1,892
Sewer	41%	\$ 1,771	\$ 1,804
Trash	14%	\$ 605	\$ 616
Community	2%	\$ 86	\$ 88
<b>Total</b>	<b>100%</b>	<b>\$ 4,320</b>	<b>\$ 4,400</b>

**GENERAL**  
**Workers' Comp Insurance**

**Account Number:** 4600  
**Budget Line Item:** 29

**Account Description:**

Monthly payments to ACW/JPIA Workman's Compensation Insurance based on total wages for employees and Board Members.

**Changes for FY 2020 - 2021:**

Continued decrease in premiums due to zero claims.

**Budget Backup**

Workers' Comp Insurance	Total	Allocation
Insurance Premium	\$ 12,000	Staff Time
<b>Total</b>	<b>\$ 12,000</b>	

**Rounded To: \$ 12,000**

2

	Adopted FY 2019 - 2020	Actual Through 3/31/2020	Projected June 2020	Proposed FY 2020 - 2021
Workers' Comp Insurance	\$ 13,000	\$ 5,117	\$ 10,920	\$ 12,000

Enterprise Allocation		Calculated	Rounded
Water	39%	\$ 4,680	\$ 4,680
Sewer	40%	\$ 4,800	\$ 4,800
Trash	19%	\$ 2,280	\$ 2,280
Community	2%	\$ 240	\$ 240
<b>Total</b>	<b>100%</b>	<b>\$ 12,000</b>	<b>\$ 12,000</b>

## GENERAL Employee Education

**Account Number:** 4650  
**Budget Line Item:** 30

**Account Description:**  
 Expenses related to tuition reimbursement programs, general trainings, and conference registration.

**Changes for FY 2020 - 2021:**  
 Adjustment to MOU for tuition reimbursement for Represented Staff up to \$2,000 per year

### Budget Backup

Employee Education	Total	Allocation
Represented Employee Tuition Reimbursement 3 @ 2000	\$ 6,000	Staff Time
Management Tuition Reimbursement (Expires FY 2021)	\$ 8,000	Staff Time
Trainings & Continuing Education	\$ 4,000	Staff Time
Conference Registration	\$ 4,000	Staff Time
<b>Total</b>	<b>\$ 22,000</b>	

Rounded To: \$ 22,000

	Adopted FY 2019 - 2020	Actual Through 3/31/2020	Projected June 2020	Proposed FY 2020 - 2021
Employee Education	\$ 18,000	\$ 15,647	\$ 16,000	\$ 22,000

Enterprise Allocation		Calculated	Rounded
Water	39%	\$ 8,580	\$ 8,580
Sewer	40%	\$ 8,800	\$ 8,800
Trash	19%	\$ 4,180	\$ 4,180
Community	2%	\$ 440	\$ 440
<b>Total</b>	<b>100%</b>	<b>\$ 22,000</b>	<b>\$ 22,000</b>



## GENERAL Regular Board Payments

**Account Number:** 5010  
**Budget Line Item:** 31

**Account Description:**  
 Boardmember compensation for Regular Board Meetings

**Changes for FY 2020 - 2021:**  
 None

### Budget Backup

Regular Board Payments	Total	Allocation
Board Compensation	\$ 9,000	<i>Staff Time</i>
<b>Total</b>	<b>\$ 9,000</b>	

**Rounded To:** \$ 9,000

	Adopted FY 2019 - 2020	Actual Through 3/31/2020	Projected June 2020	Proposed FY 2020 - 2021
Regular Board Payments	\$ 9,000	\$ 4,450	\$ 7,000	\$ 9,000

Enterprise Allocation		Calculated	Rounded
Water	39%	\$ 3,510	\$ 3,510
Sewer	40%	\$ 3,600	\$ 3,600
Trash	19%	\$ 1,710	\$ 1,710
Community	2%	\$ 180	\$ 180
<b>Total</b>	<b>100%</b>	<b>\$ 9,000</b>	<b>\$ 9,000</b>

## GENERAL Special Board Meetings

**Account Number:** 5020  
**Budget Line Item:** 32

**Account Description:**  
 Boardmember compensation for Special Board Meetings and Committee Meetings

**Changes for FY 2020 - 2021:**  
 None

### Budget Backup

Special Board Meetings	Total	Allocation
Board Compensation	\$ 2,000	<i>Staff Time</i>
<b>Total</b>	<b>\$ 2,000</b>	

**Rounded To:** \$ 2,000

	Adopted FY 2019 - 2020	Actual Through 3/31/2020	Projected June 2020	Proposed FY 2020 - 2021
Special Board Meetings	\$ 2,350	\$ 400	\$ 2,000	\$ 2,000

Enterprise Allocation		Calculated	Rounded
Water	39%	\$ 780	\$ 780
Sewer	40%	\$ 800	\$ 800
Trash	19%	\$ 380	\$ 380
Community	2%	\$ 40	\$ 40
<b>Total</b>	<b>100%</b>	<b>\$ 2,000</b>	<b>\$ 2,000</b>

## GENERAL Board/ Committee Expenses

**Account Number:** 5030  
**Budget Line Item:** 33

**Account Description:**

Board/Committee Meeting Expenses including Hollywood Beach School rental, miscellaneous supplies, Annual Volunteer Luncheon. Includes donation for Veteran's Day Event at Hollywood Beach School.

**Changes for FY 2020 - 2021:**

None

**Budget Backup**

Board/ Committee Expenses	Total	Allocation
Meeting Expenses	\$ 1,000	<i>Staff Time</i>
<b>Total</b>	<b>\$ 1,000</b>	

**Rounded To: \$ 1,000**

	Adopted FY 2019 - 2020	Actual Through 3/31/2020	Projected June 2020	Proposed FY 2020 - 2021
Board/ Committee Expenses	\$ 1,000	\$ 600	\$ 1,000	\$ 1,000

Enterprise Allocation		Calculated	Rounded
Water	39%	\$ 390	\$ 390
Sewer	40%	\$ 400	\$ 400
Trash	19%	\$ 190	\$ 190
Community	2%	\$ 20	\$ 20
<b>Total</b>	<b>100%</b>	<b>\$ 1,000</b>	<b>\$ 1,000</b>

**GENERAL**  
**Board Conferences & Seminars**

**Account Number:** 5040  
**Budget Line Item:** 34

**Account Description:**  
Registration for attendance at conferences including ACWA, CSDA, and various Mangement seminars.

**Changes for FY 2020 - 2021:**  
None

**Budget Backup**

Board Conferences & Seminars	Total	Allocation
Registration Costs	\$ 5,000	<i>Staff Time</i>
<b>Total</b>	<b>\$ 5,000</b>	

**Rounded To: \$ 5,000**

	Adopted FY 2019 - 2020	Actual Through 3/31/2020	Projected June 2020	Proposed FY 2020 - 2021
Board Conferences & Seminars	\$ 5,000	\$ 355	\$ 1,000	\$ 5,000

Enterprise Allocation		Calculated	Rounded
Water	39%	\$ 1,950	\$ 1,950
Sewer	40%	\$ 2,000	\$ 2,000
Trash	19%	\$ 950	\$ 950
Community	2%	\$ 100	\$ 100
<b>Total</b>	<b>100%</b>	<b>\$ 5,000</b>	<b>\$ 5,000</b>

## GENERAL Travel & Lodging

**Account Number:** 5050  
**Budget Line Item:** 35

**Account Description:**

Employee and Boardmember travel for education and seminars, including reimbursement for mileage and meals.

**Changes for FY 2020 - 2021:**

None

**Budget Backup**

Travel & Lodging	Total	Allocation
Travel Expenses	\$ 8,500	<i>Staff Time</i>
<b>Total</b>	<b>\$ 8,500</b>	

**Rounded To:** \$ 8,500

	Adopted FY 2019 - 2020	Actual Through 3/31/2020	Projected June 2020	Proposed FY 2020 - 2021
Travel & Lodging	\$ 8,500	\$ 6,488	\$ 6,488	\$ 8,500

Enterprise Allocation		Calculated	Rounded
Water	39%	\$ 3,315	\$ 3,315
Sewer	40%	\$ 3,400	\$ 3,400
Trash	19%	\$ 1,615	\$ 1,615
Community	2%	\$ 170	\$ 170
<b>Total</b>	<b>100%</b>	<b>\$ 8,500</b>	<b>\$ 8,500</b>

## GENERAL District Dues & Memberships

**Account Number:** 5100  
**Budget Line Item:** 36

**Account Description:**  
Annual payments for the District's membership in organizations.

**Changes for FY 2020 - 2021:**  
Increase in dues from CSDA, ACWA and LAFCO

### Budget Backup

District Dues & Memberships	Total	Allocation
Association of California Water Agencies (ACWA)	\$ 12,775	<i>Ops Time</i>
Channel Counties Water Utilities Assoc (CCWUA)	\$ 100	<i>Water Only</i>
American Water Works Association (AWWA)	\$ 475	<i>Water Only</i>
Ventura County Special Districts Association (VCSDA)	\$ 150	<i>Water Only</i>
LAFCO (District mandated share of LAFCO expense)	\$ 3,000	<i>Equal Distribution</i>
California Water Efficiency Partnership	\$ 1,350	<i>Water Only</i>
Association of Water Agencies (AWA)	\$ 300	<i>Water Only</i>
California Special District Association (CSDA)	\$ 3,800	<i>Equal Distribution</i>
California Association of Sanitation Agencies (CASA)	\$ 1,700	<i>Sewer Only</i>
<b>Total</b>	<b>\$ 23,650</b>	

**Rounded To: \$ 24,000**

	Adopted FY 2019 - 2020	Actual Through 3/31/2020	Projected June 2020	Proposed FY 2020 - 2021
District Dues & Memberships	\$ 22,000	\$ 22,040	\$ 23,650	<b>\$ 24,000</b>

Enterprise Allocation		Calculated	Rounded
Water	43%	\$ 10,112	\$ 10,262
Sewer	39%	\$ 9,250	\$ 9,387
Trash	17%	\$ 4,033	\$ 4,092
Community	1%	\$ 256	\$ 259
<b>Total</b>	<b>100%</b>	<b>\$ 23,650</b>	<b>\$ 24,000</b>

## GENERAL Office Supplies

**Account Number:** 5210  
**Budget Line Item:** 37

**Account Description:**

Office supplies for office and operations including, but not limited to: Printer & fax cartridges, copy paper, checks, printers, monitors, office furniture, etc.

**Changes for FY 2020 - 2021:**

### Budget Backup

Office Supplies	Total	Allocation
Supplies	\$ 8,000	<i>Equal Distribution</i>
<b>Total</b>	<b>\$ 8,000</b>	

**Rounded To: \$ 8,000**

	Adopted FY 2019 - 2020	Actual Through 3/31/2020	Projected June 2020	Proposed FY 2020 - 2021
Office Supplies	\$ 7,500	\$ 6,340	\$ 7,500	\$ 8,000

Enterprise Allocation		Calculated	Rounded
Water	33%	\$ 2,640	\$ 2,640
Sewer	34%	\$ 2,720	\$ 2,720
Trash	33%	\$ 2,640	\$ 2,640
Community	0%	\$ -	\$ -
<b>Total</b>	<b>100%</b>	<b>\$ 8,000</b>	<b>\$ 8,000</b>

## GENERAL On-Line Bill Paying

**Account Number:** 5215  
**Budget Line Item:** 38

**Account Description:**

Electronic Billing Software & Support. District is charged on a per-transaction basis from vendor. Costs increase based on vendor rate and adoption by District customers.

**Changes for FY 2020 - 2021:**

No increase in charges, reduced for this fiscal year.

### Budget Backup

On-Line Bill Paying	Total	Allocation
CUSI / Vanco / IVR	\$ 5,500	<i>Revenue Basis</i>
<b>Total</b>	<b>\$ 5,500</b>	

**Rounded To: \$ 6,000**

3

	Adopted FY 2019 - 2020	Actual Through 3/31/2020	Projected June 2020	Proposed FY 2020 - 2021
On-Line Bill Paying	\$ 7,000	\$ 2,796	\$ 5,000	\$ 6,000

Enterprise Allocation		Calculated	Rounded
Water	41%	\$ 2,255	\$ 2,460
Sewer	44%	\$ 2,420	\$ 2,640
Trash	15%	\$ 825	\$ 900
Community	0%	\$ -	\$ -
<b>Total</b>	<b>100%</b>	<b>\$ 5,500</b>	<b>\$ 6,000</b>



## GENERAL Communications

**Account Number:** 5220  
**Budget Line Item:** 39

**Account Description:**  
 Communications services, District website, and advertising.

**Changes for FY 2020 - 2021:**  
 Added Hughesnet Sattelite subscription as backup to primary cable internet connection.

### Budget Backup

Communications	Total	Allocation
Frontier	\$ 1,700	<i>Equal Distribution</i>
Spectrum TV	\$ 600	<i>Equal Distribution</i>
Hughesnet Sattelite	\$ 600	<i>Equal Distribution</i>
Spectrum Internet	\$ 2,700	<i>Equal Distribution</i>
AT&T	\$ 8,000	<i>Equal Distribution</i>
Streamline	\$ 2,400	<i>Equal Distribution</i>
Miscellaneous	\$ 1,000	<i>Equal Distribution</i>
<b>Total</b>	<b>\$ 17,000</b>	

**Rounded To: \$ 17,000**

	Adopted FY 2019 - 2020	Actual Through 3/31/2020	Projected June 2020	Proposed FY 2020 - 2021
Communications	\$ 16,000	\$ 12,416	\$ 15,750	\$ 17,000

Enterprise Allocation		Calculated	Rounded
Water	33%	\$ 5,610	\$ 5,610
Sewer	34%	\$ 5,780	\$ 5,780
Trash	33%	\$ 5,610	\$ 5,610
Community	0%	\$ -	\$ -
<b>Total</b>	<b>100%</b>	<b>\$ 17,000</b>	<b>\$ 17,000</b>

## GENERAL *Printing & Publications*

**Account Number:** 5230  
**Budget Line Item:** 40

**Account Description:**  
Printing and binding expenses for envelopes, letterhead, business cards, billing statements and related envelopes.

**Changes for FY 2020 - 2021:**  
None

### Budget Backup

Printing & Publications	Total	Allocation
Printing Expenses	\$ 6,000	<i>Equal Distribution</i>
<b>Total</b>	<b>\$ 6,000</b>	

**Rounded To:** \$ 6,000

	Adopted FY 2019 - 2020	Actual Through 3/31/2020	Projected June 2020	Proposed FY 2020 - 2021
Printing & Publications	\$ 6,000	\$ 2,149	\$ 5,000	\$ 6,000

Enterprise Allocation		Calculated	Rounded
Water	33%	\$ 1,980	\$ 1,980
Sewer	34%	\$ 2,040	\$ 2,040
Trash	33%	\$ 1,980	\$ 1,980
Community	0%	\$ -	\$ -
<b>Total</b>	<b>100%</b>	<b>\$ 6,000</b>	<b>\$ 6,000</b>

**GENERAL**  
**Postage & Shipping**

**Account Number:** 5240  
**Budget Line Item:** 41

**Account Description:**

Mailing costs for billing statements sent via metered postage and miscellaneous shipping via FedEx and UPS.

**Changes for FY 2020 - 2021:**

Reduction in cost due to increase in paperless statements.

**Budget Backup**

<b>Postage &amp; Shipping</b>	Total	Allocation
Postage Expenses	\$ 12,000	<i>Equal Distribution</i>
<b>Total</b>	<b>\$ 12,000</b>	

**Rounded To: \$ 12,000**

3

	Adopted FY 2019 - 2020	Actual Through 3/31/2020	Projected June 2020	Proposed FY 2020 - 2021
Postage & Shipping	\$ 15,000	\$ 7,000	\$ 11,000	\$ 12,000

<b>Enterprise Allocation</b>		<b>Calculated</b>	<b>Rounded</b>
Water	33%	\$ 3,960	\$ 3,960
Sewer	34%	\$ 4,080	\$ 4,080
Trash	33%	\$ 3,960	\$ 3,960
Community	0%	\$ -	\$ -
<b>Total</b>	<b>100%</b>	<b>\$ 12,000</b>	<b>\$ 12,000</b>

**GENERAL**  
**Miscellaneous Office Expense**

**Account Number:** 5250  
**Budget Line Item:** 42

**Account Description:**

Postage machine, payroll, and check courier costs. Also includes miscellaneous office supplies, kitchen & restroom supplies, newspaper subscriptions, employee recognition, luncheons and other miscellaneous expenses.

**Changes for FY 2020 - 2021:**

Small increases in all line items.

**Budget Backup**

Miscellaneous Office Expense	Total	Allocation
Courier Service	\$ 3,000	Revenue Basis
Postage machine rental	\$ 2,100	Revenue Basis
Payroll Service	\$ 2,600	Staff Time
Miscellaneous Office	\$ 7,000	Revenue Basis
<b>Total</b>	<b>\$ 14,700</b>	

**Rounded To: \$ 14,700**

2

	Adopted FY 2019 - 2020	Actual Through 3/31/2020	Projected June 2020	Proposed FY 2020 - 2021
Miscellaneous Office Expense	\$ 13,200	\$ 9,688	\$ 13,700	\$ 14,700

Enterprise Allocation		Calculated	Rounded
Water	41%	\$ 5,975	\$ 5,975
Sewer	43%	\$ 6,364	\$ 6,364
Trash	16%	\$ 2,309	\$ 2,309
Community	0%	\$ 52	\$ 52
<b>Total</b>	<b>100%</b>	<b>\$ 14,700</b>	<b>\$ 14,700</b>

## GENERAL Office Utilities

**Account Number:** 5260  
**Budget Line Item:** 43

**Account Description:**  
 Utility charges for District office.

**Changes for FY 2020 - 2021:**  
 None

### Budget Backup

Office Utilities	Total	Allocation
Utilities	\$ 3,800	<i>Equal Distribution</i>
<b>Total</b>	<b>\$ 3,800</b>	

**Rounded To:** \$ 3,800

2

	Adopted FY 2019 - 2020	Actual Through 3/31/2020	Projected June 2020	Proposed FY 2020 - 2021
Office Utilities	\$ 3,800	\$ 2,132	\$ 3,500	\$ 3,800

Enterprise Allocation		Calculated	Rounded
Water	33%	\$ 1,254	\$ 1,254
Sewer	34%	\$ 1,292	\$ 1,292
Trash	33%	\$ 1,254	\$ 1,254
Community	0%	\$ -	\$ -
<b>Total</b>	<b>100%</b>	<b>\$ 3,800</b>	<b>\$ 3,800</b>

## GENERAL Office Equipment Maintenance

**Account Number:** 5290  
**Budget Line Item:** 44

**Account Description:**

Annual and monthly maintenance contract charges, service and miscellaneous parts and unanticipated repairs for equipment not covered by a contract.

**Changes for FY 2020 - 2021:**

Small Increases in all line items.

### Budget Backup

Office Equipment Maintenance	Total	Allocation
Image Source Maintenance	\$ 1,680	<i>Equal Distribution</i>
Xerox Maintenance	\$ 3,500	<i>Equal Distribution</i>
Small Printer Maintenance	\$ 900	<i>Equal Distribution</i>
Folding Machine Maintenance	\$ 2,200	<i>Equal Distribution</i>
<b>Total</b>	<b>\$ 8,280</b>	

**Rounded To: \$ 9,000**

3

	Adopted FY 2019 - 2020	Actual Through 3/31/2020	Projected June 2020	Proposed FY 2020 - 2021
Office Equipment Maintenance	\$ 8,000	\$ 5,730	\$ 9,000	\$ 9,000

Enterprise Allocation		Calculated	Rounded
Water	33%	\$ 2,435	\$ 2,970
Sewer	34%	\$ 2,509	\$ 3,060
Trash	33%	\$ 2,435	\$ 2,970
Community	0%	\$ -	\$ -
<b>Total</b>	<b>100%</b>	<b>\$ 7,380</b>	<b>\$ 9,000</b>

## GENERAL General Capital Replacement

**Account Number:** 5295  
**Budget Line Item:** 45

**Account Description:**  
 Capital Replacement for small equipment items, under \$15,000.

**Changes for FY 2020 - 2021:**  
 Moved large equipment items to CIP Budget

### Budget Backup

Gener	Unit Cost	Total	Allocation
Computers	\$ 3,000	\$ 3,000	Equal Distribution
Miscellaneous	\$ 5,000	\$ 5,000	Rev. Water/Sewer
		\$ -	Rev. Water/Sewer
		\$ -	Equal Distribution
<b>Total</b>		<b>\$ 8,000</b>	

**Rounded To:** \$ 8,000

3

	Adopted FY 2019 - 2020	Actual Through 3/31/2020	Projected June 2020	Proposed FY 2020 - 2021
General Capital Replacement	\$ 49,000	\$ 3,000	\$ 3,000	\$ 8,000

Enterprise Allocation		Calculated	Rounded
Water	33%	\$ 990	\$ 2,640
Sewer	34%	\$ 1,020	\$ 2,720
Trash	33%	\$ 990	\$ 2,640
Community	0%	\$ -	\$ -
<b>Total</b>	<b>100%</b>	<b>\$ 3,000</b>	<b>\$ 8,000</b>

## GENERAL Insurance

**Account Number:** 5400  
**Budget Line Item:** 46

**Account Description:**

Property and general liability insurance through Association of California Water Agencies/Joint Powers Insurance Authority (ACWA/JPIA).

**Changes for FY 2020 - 2021:**

Additional coverage for Flood Insurance.

### Budget Backup

Insurance	Total	Allocation
General Liability	\$ 32,100	<i>Revenue Basis</i>
Additional Flood Coverage	\$ 6,000	<i>Revenue Basis</i>
Fidelity Bond Coverage	\$ 900	<i>Revenue Basis</i>
<b>Total</b>	<b>\$ 39,000</b>	

**Rounded To: \$ 39,000**

	Adopted FY 2019 - 2020	Actual Through 3/31/2020	Projected June 2020	Proposed FY 2020 - 2021
Insurance	\$ 39,000	\$ 27,911	\$ 37,000	\$ 39,000

Enterprise Allocation		Calculated	Rounded
Water	41%	\$ 15,990	\$ 15,990
Sewer	44%	\$ 17,160	\$ 17,160
Trash	15%	\$ 5,850	\$ 5,850
Community	0%	\$ -	\$ -
<b>Total</b>	<b>100%</b>	<b>\$ 39,000</b>	<b>\$ 39,000</b>



## GENERAL Legal Services

**Account Number:** 5510  
**Budget Line Item:** 47

**Account Description:**  
 Professional legal services for District Counsel and Special Counsel.

**Changes for FY 2020 - 2021:**  
 Special Counsel now co-representing PHWA. Work will still need to be done solely on behalf of District.

### Budget Backup

Legal Services	Total	Allocation
A to Z Law - District Counsel	\$ 40,000	<i>Revenue Basis</i>
Hollister & Brace - Special Counsel	\$ 20,000	<i>Water Only</i>
<b>Total</b>	<b>\$ 60,000</b>	

**Rounded To: \$ 60,000**

3

	Adopted FY 2019 - 2020	Actual Through 3/31/2020	Projected June 2020	Proposed FY 2020 - 2021
Legal Services	\$ 60,000	\$ 20,836	\$ 40,000	\$ 60,000

Enterprise Allocation		Calculated	Rounded
Water	61%	\$ 36,400	\$ 36,400
Sewer	29%	\$ 17,600	\$ 17,600
Trash	10%	\$ 6,000	\$ 6,000
Community	0%	\$ -	\$ -
<b>Total</b>	<b>100%</b>	<b>\$ 60,000</b>	<b>\$ 60,000</b>

## GENERAL Accounting Services

**Account Number:** 5520  
**Budget Line Item:** 48

**Account Description:**

Accounting services including staff training and support, budget preparation, audit preparation and review, bond issues, LGFA preparation, 1099's, refinancing, contract analysis, maintain fixed asset records, etc.

**Changes for FY 2020 - 2021:**

Small increase in fees.

### Budget Backup

Accounting Services	Total	Allocation
Soares, Sandall, Bernacchi & Petrovich, LLP	\$ 32,000	<i>Revenue Basis</i>
Annual Audit	\$ 18,500	<i>Revenue Basis</i>
<b>Total</b>	<b>\$ 50,500</b>	

**Rounded To: \$ 51,000**

	Adopted FY 2019 - 2020	Actual Through 3/31/2020	Projected June 2020	Proposed FY 2020 - 2021
Accounting Services	\$ 48,000	\$ 44,115	\$ 49,000	\$ 51,000

Enterprise Allocation		Calculated	Rounded
Water	41%	\$ 20,705	\$ 20,910
Sewer	44%	\$ 22,220	\$ 22,440
Trash	15%	\$ 7,575	\$ 7,650
Community	0%	\$ -	\$ -
<b>Total</b>	<b>100%</b>	<b>\$ 50,500</b>	<b>\$ 51,000</b>

## GENERAL Computer Services & Subscriptions

**Account Number:** 5530  
**Budget Line Item:** 49

**Account Description:**  
Professional IT-related services and software subscriptions.

**Changes for FY 2020 - 2021:**  
Addition of Asset Management Program and GIS Subscription, Board Approved

### Budget Backup

Computer Services & Subscriptions	Total	Allocation
<b>Affordable Service</b>	\$ 2,400	<i>Revenue Basis</i>
ZWorld GIS Subscription	\$ 10,000	<i>Revenue Basis</i>
Asset Management Program	\$ 13,000	<i>Revenue Basis</i>
CUSI Annual Support/Cloud Jumper Subscriptions	\$ 13,000	<i>Revenue Basis</i>
Antivirus & Web Security	\$ 1,000	<i>Revenue Basis</i>
Adobe	\$ 1,000	<i>Revenue Basis</i>
Microsoft	\$ 5,000	<i>Revenue Basis</i>
IT Services and Consulting/Computer Purchase	\$ 6,000	<i>Revenue Basis</i>
<b>Total</b>	<b>\$ 51,400</b>	

**Rounded To: \$ 52,000**

	Adopted FY 2019 - 2020	Actual Through 3/31/2020	Projected June 2020	Proposed FY 2020 - 2021
Computer Services & Subscriptions	\$ 19,000	\$ 21,549	\$ 26,000	<b>\$ 52,000</b>

Enterprise Allocation		Calculated	Rounded
Water	41%	\$ 5,330	\$ 21,320
Sewer	44%	\$ 5,720	\$ 22,880
Trash	15%	\$ 1,950	\$ 7,800
Community	0%	\$ -	\$ -
<b>Total</b>	<b>100%</b>	<b>\$ 13,000</b>	<b>\$ 52,000</b>

## GENERAL Engineering Services

**Account Number:** 5540  
**Budget Line Item:** 50

**Account Description:**

Professional Engineering Consulting Services not associated with an identified project in the Capital Improvement Program Budget. Fiscal Year Board approved increase to \$75,000

**Changes for FY 2020 - 2021:**

None

### Budget Backup

Engineering Services	Total	Allocation
MKN and Associates	\$ 75,000	<i>Revenue Basis</i>
		<i>Revenue Basis</i>
<b>Total</b>	<b>\$ 75,000</b>	

Rounded To: \$ 75,000

	Adopted FY 2019 - 2020	Actual Through 3/31/2020	Projected June 2020	Proposed FY 2020 - 2021
Engineering Services	\$ 60,000	\$ 32,690	\$ 75,000	\$ 75,000

Enterprise Allocation		Calculated	Rounded
Water	41%	\$ 30,750	\$ 30,750
Sewer	44%	\$ 33,000	\$ 33,000
Trash	15%	\$ 11,250	\$ 11,250
Community	0%	\$ -	\$ -
<b>Total</b>	<b>100%</b>	<b>\$ 75,000</b>	<b>\$ 75,000</b>

**GENERAL**  
**Bank & Trustee Fees**

**Account Number:** 5560  
**Budget Line Item:** 51

**Account Description:**  
Bank and Trustee Fees

**Changes for FY 2020 - 2021:**

**Budget Backup**

Bank & Trustee Fees	Total	Allocation
Expenses	\$ 4,000	<i>Revenue Basis</i>
<b>Total</b>	<b>\$ 4,000</b>	

**Rounded To: \$ 4,000**

	Adopted FY 2019 - 2020	Actual Through 3/31/2020	Projected June 2020	Proposed FY 2020 - 2021
Bank & Trustee Fees	\$ 4,000	\$ 2,500	\$ 4,000	\$ 4,000

Enterprise Allocation		Calculated	Rounded
Water	41%	\$ 1,640	\$ 1,640
Sewer	44%	\$ 1,760	\$ 1,760
Trash	15%	\$ 600	\$ 600
Community	0%	\$ -	\$ -
<b>Total</b>	<b>100%</b>	<b>\$ 4,000</b>	<b>\$ 4,000</b>

## GENERAL Other Professional Services

**Account Number:** 5565  
**Budget Line Item:** 52

**Account Description:**

Professional services, including, but not limited to: framing, large format scanning, specialty printing, shredding, appraisals, various studies as needed and consultants. Board approved additional \$25,000 for current fiscal year.

**Changes for FY 2020 - 2021:**

Increase due GIS Support Services

### Budget Backup

Other Professional Services	Total	Allocation
Expenses	\$ 30,000	<i>Revenue Basis</i>
<b>Total</b>	<b>\$ 30,000</b>	

**Rounded To: \$ 30,000**

3

	Adopted FY 2019 - 2020	Actual Through 3/31/2020	Projected June 2020	Proposed FY 2020 - 2021
Other Professional Services	\$ 10,000	\$ 24,708	\$ 30,000	\$ 30,000

Enterprise Allocation		Calculated	Rounded
Water	41%	\$ 12,300	\$ 12,300
Sewer	44%	\$ 13,200	\$ 13,200
Trash	15%	\$ 4,500	\$ 4,500
Community	0%	\$ -	\$ -
<b>Total</b>	<b>100%</b>	<b>\$ 30,000</b>	<b>\$ 30,000</b>

**GENERAL**  
**Legal Notices Publication**

**Account Number:** 5600  
**Budget Line Item:** 53

**Account Description:**  
Expenses incurred by public legal notices as required by State Law.

**Changes for FY 2020 - 2021:**  
Program is higher in election years and lower in non-election years.

**Budget Backup**

Legal Notices Publication	Total	Allocation
Public Notices	\$ 1,500	<i>Equal Distribution</i>
Board Elections	\$ 4,000	<i>Equal Distribution</i>
Ordinances and Notifications	\$ 1,000	<i>Equal Distribution</i>
<b>Total</b>	<b>\$ 6,500</b>	

**Rounded To: \$ 7,000**

	Adopted FY 2019 - 2020	Actual Through 3/31/2020	Projected June 2020	Proposed FY 2020 - 2021
Legal Notices Publication	\$ 3,000	\$ 637	\$ 1,500	\$ 7,000

Enterprise Allocation		Calculated	Rounded
Water	33%	\$ 495	\$ 2,310
Sewer	34%	\$ 510	\$ 2,380
Trash	33%	\$ 495	\$ 2,310
Community	0%	\$ -	\$ -
<b>Total</b>	<b>100%</b>	<b>\$ 1,500</b>	<b>\$ 7,000</b>

**GENERAL**  
**Public Information & Outreach**

**Account Number:** 5650  
**Budget Line Item:** 54

**Account Description:**  
Customer Outreach and Public Information Costs

**Changes for FY 2020 - 2021:**  
Records Management project was put on hold during FY 2019 - 2020 and will be resumed during FY 2020 - 2021

**Budget Backup**

Public Information & Outreach	Total	Allocation
Website Domain Fee	\$ 180	<i>Equal Distribution</i>
Additional Mailer	\$ 1,400	<i>Equal Distribution</i>
Graphic Design Services for Outreach Materials	\$ 3,000	<i>Equal Distribution</i>
Social Media Ad Buys	\$ 800	<i>Equal Distribution</i>
Laserfiche Subscription	\$ 4,000	<i>Equal Distribution</i>
Miscellaneous Records Management	\$ 2,500	<i>Equal Distribution</i>
General Notification Costs	\$ 1,600	<i>Equal Distribution</i>
<b>Total</b>	<b>\$ 13,480</b>	

**Rounded To: \$ 14,000**

	Adopted FY 2019 - 2020	Actual Through 3/31/2020	Projected June 2020	Proposed FY 2020 - 2021
Public Information & Outreach	\$ 14,000	\$ 5,231	\$ 8,000	<b>\$ 14,000</b>

Enterprise Allocation		Calculated	Rounded
Water	33%	\$ 59	\$ 4,620
Sewer	34%	\$ 61	\$ 4,760
Trash	33%	\$ 59	\$ 4,620
Community	0%	\$ -	\$ -
<b>Total</b>	<b>100%</b>	<b>\$ 180</b>	<b>\$ 14,000</b>



**NON-RATE REVENUE**  
***Interest Earnings***

**Account Number:** 6100  
**Budget Line Item:** 55

**Account Description:**

Interest income from fund balances held with County Fund. Earnings are allocated at the end of the fiscal year based on interest earned by each Enterprise.

**Changes for FY 2020 - 2021:**

Income based on market performance.

**Budget Backup**

Interest Earnings	Total	Allocation
Interest Earnings	\$ 90,000	<i>Interest Earnings</i>
<b>Total</b>	<b>\$ 90,000</b>	

**Rounded To: \$ 90,000**

3

	Adopted FY 2019 - 2020	Actual Through 3/31/2019	Projected June 2020	Proposed FY 2020 - 2021
Interest Earnings	\$ 38,000	\$ 115,965	\$ 125,000	\$ <b>90,000</b>

Enterprise Allocation		Calculated	Rounded
Water	35%	\$ 31,500	\$ 31,500
Sewer	55%	\$ 49,500	\$ 49,500
Trash	10%	\$ 9,000	\$ 9,000
Community	0%	\$ -	\$ -
<b>Total</b>	<b>100%</b>	<b>\$ 90,000</b>	<b>\$ 90,000</b>

## NON-RATE REVENUE

### *Penalty Revenue*

**Account Number:** 6200  
**Budget Line Item:** 56

**Account Description:**  
 Revenue generated from late and delinquent payments.

**Changes for FY 2020 - 2021:**  
 Majority of penalty revenue is used to offset Community Service activity costs. A portion of penalty revenue is allocated to each enterprise to cover costs of payment collection.

#### Budget Backup

Penalty Revenue	Total	Allocation
Late Payment Revenue	\$ 25,000	<i>Custom 3</i>
<b>Total</b>	<b>\$ 25,000</b>	

**Rounded To:** \$ 25,000  
 3

	Adopted FY 2019 - 2020	Actual Through 3/31/2020	Projected June 2020	Proposed FY 2020 - 2021
Penalty Revenue	\$ 25,000	\$ 13,916	\$ 15,000	\$ 25,000

Enterprise Allocation		Calculated	Rounded
Water	10%	\$ 2,500	\$ 2,500
Sewer	10%	\$ 2,500	\$ 2,500
Trash	10%	\$ 2,500	\$ 2,500
Community	70%	\$ 17,500	\$ 17,500
<b>Total</b>	<b>100%</b>	<b>\$ 25,000</b>	<b>\$ 25,000</b>

## NON-RATE REVENUE *Secured & Unsecured Taxes*

**Account Number:** 6320  
**Budget Line Item:** 57

**Account Description:**

District's portion of 1% Ad Valorem Property Tax collected from properties within District's service area. Funds are held by County of Ventura.

**Changes for FY 2020 - 2021:**

**Budget Backup**

Secured & Unsecured Taxes	Total	Allocation
Tax Income	\$ 66,000	<i>Comm Svc Only</i>
<b>Total</b>	<b>\$ 66,000</b>	

**Rounded To: \$ 66,000**

3

	Adopted FY 2019 - 2020	Actual Through 3/31/2020	Projected June 2020	Proposed FY 2020 - 2021
Secured & Unsecured Taxes	\$ 66,000	\$ 46,080	\$ 65,000	<b>\$ 66,000</b>

Enterprise Allocation		Calculated	Rounded
Water	0%	\$ -	\$ -
Sewer	0%	\$ -	\$ -
Trash	0%	\$ -	\$ -
Community	100%	\$ 66,000	\$ 66,000
<b>Total</b>	<b>100%</b>	<b>\$ 66,000</b>	<b>\$ 66,000</b>

## DEBT SERVICE 2012 Water Revenue Bonds

**Account Number:** 2805  
**Budget Line Item:** 58

**Account Description:**

Annual debt service for 2012 Water Revenue Bonds, initially issued for District’s capacity share in PHWA. Debt service set to retire in FY 2021 - 2022. Payments are based on a predetermined debt schedule for the life of the bond.

**Changes for FY 2020 - 2021:**

### Budget Backup

2012 Water Revenue Bonds	Total	Allocation
Certificate of Participation	\$ 310,453	<i>Water Only</i>
<b>Total</b>	<b>\$ 310,453</b>	

**Rounded To: \$ 311,000**

3

	Adopted FY 2019 - 2020	Actual Through 3/31/2020	Projected June 2020	Proposed FY 2020 - 2021
2012 Water Revenue Bonds	\$ 313,000	\$ 312,834	\$ 312,834	\$ 311,000

Enterprise Allocation		Calculated	Rounded
Water	100%	\$ 310,453	\$ 311,000
Sewer	0%	\$ -	\$ -
Trash	0%	\$ -	\$ -
Community	0%	\$ -	\$ -
<b>Total</b>	<b>100%</b>	<b>\$ 310,453</b>	<b>\$ 311,000</b>

**\$2,716,072**

CHANNEL ISLANDS BEACH COMMUNITY SERVICE DISTRICT

2012 Water Revenue Refunding COP

FINAL NUMBERS - JUNE 7, 2012

**Debt Service Schedule**

Date	Principal	Coupon	Interest	Total P+I
09/01/2012	256,961.34	3.050%	18,178.82	275,140.16
03/01/2013	-	-	37,501.44	37,501.44
09/01/2013	240,983.73	3.050%	37,501.44	278,485.17
03/01/2014	-	-	33,826.44	33,826.44
09/01/2014	252,402.87	3.050%	33,826.44	286,229.31
03/01/2015	-	-	29,977.30	29,977.30
09/01/2015	258,288.41	3.050%	29,977.30	288,265.71
03/01/2016	-	-	26,038.40	26,038.40
09/01/2016	263,630.18	3.050%	26,038.40	289,668.58
03/01/2017	-	-	22,018.04	22,018.04
09/01/2017	272,960.69	3.050%	22,018.04	294,978.73
03/01/2018	-	-	17,855.39	17,855.39
09/01/2018	281,332.41	3.050%	17,855.39	299,187.80
03/01/2019	-	-	13,565.07	13,565.07
09/01/2019	289,239.88	3.050%	13,565.07	302,804.95
03/01/2020	-	-	9,154.16	9,154.16
09/01/2020	296,668.74	3.050%	9,154.16	305,822.90
03/01/2021	-	-	4,629.96	4,629.96
09/01/2021	303,604.15	3.050%	4,629.96	308,234.11
03/01/2022	-	3.050%	-	-
<b>Total</b>	<b>\$2,716,072.40</b>	<b>-</b>	<b>\$407,311.22</b>	<b>\$3,123,383.62</b>

**Yield Statistics**

Bond Year Dollars	\$13,354.47
Average Life	4.917 Years
Average Coupon	3.0499999%
Net Interest Cost (NIC)	3.0499999%
True Interest Cost (TIC)	3.0506377%
Bond Yield for Arbitrage Purposes	3.0506377%
All Inclusive Cost (AIC)	3.3850908%

**IRS Form 8038**

Net Interest Cost	3.0499999%
Weighted Average Maturity	4.917 Years

## DEBT SERVICE 2016 Sewer Refunding Bonds

**Account Number:** 2855  
**Budget Line Item:** 59

**Account Description:**

Annual debt service for 2016 Sewer Bonds. Payments are based on a predetermined debt schedule for the life of the bond until 2032. Bonds initially issued for rehabilitation of sewer forcemain along Victoria and Channel Islands Boulevard.

**Changes for FY 2020 - 2021:**

### Budget Backup

2016 Sewer Refunding Bonds	Total	Allocation
Debt Service	\$ 219,197	<i>Sewer Only</i>
<b>Total</b>	<b>\$ 219,197</b>	

**Rounded To: \$ 220,000**

	Adopted FY 2019 - 2020	Actual Through 3/31/2020	Projected June 2020	Proposed FY 2020 - 2021
2016 Sewer Refunding Bonds	\$ 191,000	\$ 146,290	\$ 186,991	\$ 220,000

Enterprise Allocation		Calculated	Rounded
Water	0%	\$ -	\$ -
Sewer	100%	\$ 219,197	\$ 220,000
Trash	0%	\$ -	\$ -
Community	0%	\$ -	\$ -
<b>Total</b>	<b>100%</b>	<b>\$ 219,197</b>	<b>\$ 220,000</b>

**CHANNEL ISLANDS BEACH COMMUNITY SERVICES DISTRICT  
 SERIES 2016 WASTEWATER REVENUE REFUNDING BONDS  
 (REFINANCING OF 2005 WASTEWATER BONDS)**

closing

	Principal	Rate	Interest	Total Payment	Annual Debt Service
5/1/2017			\$ 49,750.07	\$ 49,750.07	
11/1/2017	95,000	2.00%	\$ 42,240.63	\$ 137,240.63	\$ 186,990.69
5/1/2018			\$ 41,290.63	\$ 41,290.63	
11/1/2018	105,000	2.00%	\$ 41,290.63	\$ 146,290.63	\$ 187,581.25
5/1/2019			\$ 40,240.63	\$ 40,240.63	
11/1/2019	110,000	3.00%	\$ 40,240.63	\$ 150,240.63	\$ 190,481.25
5/1/2020			\$ 38,590.63	\$ 38,590.63	
11/1/2020	105,000	3.00%	\$ 38,590.63	\$ 143,590.63	\$ 182,181.25
5/2/2021			\$ 37,015.63	\$ 37,015.63	
11/2/2021	110,000	3.000%	\$ 37,015.63	\$ 147,015.63	\$ 184,031.25
5/2/2022			\$ 35,365.63	\$ 35,365.63	
11/2/2022	115,000	4.000%	\$ 35,365.63	\$ 150,365.63	\$ 185,731.25
5/2/2023			\$ 33,065.63	\$ 33,065.63	
11/2/2023	120,000	4.000%	\$ 33,065.63	\$ 153,065.63	\$ 186,131.25
5/1/2024			\$ 30,665.63	\$ 30,665.63	
11/1/2024	125,000	4.000%	\$ 30,665.63	\$ 155,665.63	\$ 186,331.25
5/2/2025			\$ 28,165.63	\$ 28,165.63	
11/2/2025	130,000	4.000%	\$ 28,165.63	\$ 158,165.63	\$ 186,331.25
5/2/2026			\$ 25,565.63	\$ 25,565.63	
11/2/2026	135,000	4.000%	\$ 25,565.63	\$ 160,565.63	\$ 186,131.25
5/2/2027			\$ 22,865.63	\$ 22,865.63	
11/2/2027	140,000	4.000%	\$ 22,865.63	\$ 162,865.63	\$ 185,731.25
5/1/2028			\$ 20,065.63	\$ 20,065.63	
11/1/2028	145,000	4.000%	\$ 20,065.63	\$ 165,065.63	\$ 185,131.25
5/2/2029			\$ 17,165.63	\$ 17,165.63	
11/2/2029	150,000	4.000%	\$ 17,165.63	\$ 167,165.63	\$ 184,331.25
5/2/2030			\$ 14,165.63	\$ 14,165.63	
11/2/2030	160,000	2.500%	\$ 14,165.63	\$ 174,165.63	\$ 188,331.25
5/2/2031			\$ 12,165.63	\$ 12,165.63	
11/2/2031	165,000	2.625%	\$ 12,165.63	\$ 177,165.63	\$ 189,331.25
5/1/2032			\$ 10,000.00	\$ 10,000.00	
11/1/2032	165,000	2.750%	\$ 10,000.00	\$ 175,000.00	\$ 185,000.00
5/2/2033			\$ 7,731.25	\$ 7,731.25	
11/2/2033	175,000	2.750%	\$ 7,731.25	\$ 182,731.25	\$ 190,462.50
5/2/2034			\$ 5,325.00	\$ 5,325.00	
11/2/2034	175,000	3.000%	\$ 5,325.00	\$ 180,325.00	\$ 185,650.00
5/2/2035			\$ 2,700.00	\$ 2,700.00	
11/2/2035	180,000	3.000%	\$ 2,700.00	\$ 182,700.00	\$ 185,400.00

## DEBT SERVICE CSDA Loan - Smart Meter Project

**Account Number:** 2855  
**Budget Line Item:** 60

**Account Description:**

Annual debt service for Smart Meter Project loan through CSDA Financing Corp. Total loan amount of \$700,000 is set at a 10-year term beginning in FY 2020 and expiring in FY 2029 at an interest rate of 3.4%.

**Changes for FY 2020 - 2021:**

None

### Budget Backup

CSDA Loan - Smart Meter Project	Total	Allocation
Debt Service	\$ 84,807	<i>Rev. Water/Sewer</i>
<b>Total</b>	<b>\$ 84,807</b>	

**Rounded To: \$ 85,000**

3

	Adopted FY 2019 - 2020	Actual Through 3/31/2020	Projected June 2020	Proposed FY 2020 - 2021
CSDA Loan - Smart Meter Project	\$ 85,000	\$ 85,000	\$ 85,000	\$ 85,000

Enterprise Allocation		Calculated	Rounded
Water	49%	\$ 41,131	\$ 41,225
Sewer	52%	\$ 43,676	\$ 43,775
Trash	0%	\$ -	\$ -
Community	0%	\$ -	\$ -
<b>Total</b>	<b>100%</b>	<b>\$ 84,807</b>	<b>\$ 85,000</b>



**OTHER**  
**Allocation of Community Service**

**Account Number:** N/A  
**Budget Line Item:** 61

**Account Description:**  
Funds required from each Enterprise to fund Community Service activities.

**Changes for FY 2020 - 2021:**

**Budget Backup**

Allocation of Community Service	Total	Allocation
Required Allocation	\$ 50,000	<i>Rev. Water/Sewer</i>
<b>Total</b>	<b>\$ 50,000</b>	

**Rounded To: \$ 50,000**

3

	Adopted FY 2019 - 2020	Actual Through 3/31/2020	Projected June 2020	Proposed FY 2020 - 2021
Allocation of Community Service	\$ 50,000	\$ -	\$ -	\$ 50,000

Enterprise Allocation		Calculated	Rounded
Water	49%	\$ 24,250	\$ 24,250
Sewer	52%	\$ 25,750	\$ 25,750
Trash	0%	\$ -	\$ -
Community	0%	\$ -	\$ -
<b>Total</b>	<b>100%</b>	<b>\$ 50,000</b>	<b>\$ 50,000</b>

**FY 2020 - 2021 CAPITAL IMPROVEMENT PROGRAM**

Line	Project No.	Capital Project	Water	Sewer	Expended	FY 2021	FY 2022	FY 2023	FY 2024	FY 2025	5-Year Total
1	CI 101	Water Line Easement Evaluation	100%		\$0	\$20,000	\$40,000	\$0	\$0	\$0	\$60,000
2	CI 102	AMI Installation on Well	100%		\$5,000	\$0	\$0	\$0	\$0	\$0	\$5,000
3	CI 103	PHWA Improvements	100%		\$0	\$64,740	\$116,700	\$117,810	\$55,650	\$32,250	\$387,150
4	CI 105	Water Distribution Improvements	100%		\$0	\$50,000	\$50,000	\$50,000	\$50,000	\$50,000	\$250,000
5	CI 201	I&I Reduction - Main & Manhole Improvements		100%	\$59,309	\$481,000	\$0	\$30,000	\$266,000	\$0	\$836,309
6	CI 202	Sewer Lift Station and Pump Station Rehabilitation		100%	\$35,000	\$190,000	\$100,000	\$320,000	\$100,000	\$0	\$745,000
7	CI 205	Hydrogen Sulfide Reduction		100%	\$0	\$0	\$100,000	\$0	\$0	\$0	\$100,000
8	CI 206	Oxnard Wastewater Plant Improvements		100%	\$0	\$200,000	\$200,000	\$300,000	\$600,000	\$0	\$1,300,000
9	CI 208	Wastewater Flow Meter Insallation		100%	\$9,000	\$10,000	\$0	\$0	\$0	\$0	\$19,000
10	CI 402	Yard and Building Improvements	50%	50%	\$40,000	\$100,000	\$1,450,000	\$0	\$0	\$0	\$1,590,000
11	CI 403	Asset Management Software Program	50%	50%	\$0	\$31,000	\$0	\$0	\$0	\$0	\$31,000
12	CI 501	Air Compressor	50%	50%	\$10,000	\$0	\$0	\$0	\$0	\$0	\$10,000
13	CI 502	Changeable Message Sign	50%	50%	\$15,000	\$0	\$0	\$0	\$0	\$0	\$15,000
14	CI 503	Vehicle Replacement - 2001 Crane Truck	50%	50%	\$0	\$150,000	\$0	\$0	\$0	\$0	\$150,000
15	MI 104	Water Emergency Response Plan	100%		\$0	\$12,000	\$0	\$0	\$0	\$0	\$12,000
16	MI 105	Water & Sewer Master Plan	50%	50%	\$0	\$75,000	\$0	\$0	\$0	\$0	\$75,000
17	MI 204	CCTV Video Inspection Program		100%	\$0	\$0	\$0	\$0	\$85,000	\$0	\$85,000
18	MI 209	Sewer System Management Plan		100%	\$5,000	\$0	\$0	\$0	\$0	\$0	\$5,000
19	MI 404	Water & Sewer Rate Study	50%	50%	\$5,000	\$35,000	\$0	\$0	\$0	\$0	\$35,000
<b>Water</b>					\$40,000	\$342,240	\$931,700	\$167,810	\$105,650	\$82,250	\$1,629,650
<b>Sewer</b>					\$143,309	\$1,076,500	\$1,125,000	\$650,000	\$1,051,000	\$0	\$3,902,500
<b>Trash</b>					\$0	\$0	\$0	\$0	\$0	\$0	\$0
<b>Total</b>					<b>\$183,309</b>	<b>\$1,418,740</b>	<b>\$2,056,700</b>	<b>\$817,810</b>	<b>\$1,156,650</b>	<b>\$82,250</b>	<b>\$5,532,150</b>

**Water Enterprise**

**FY 2021**

Beginning Capital Reserve Balance	\$3,582,268
Contributions for FY 2020 - 2021:	\$219,000
Planned Capital Expenditures	-\$342,240
<b>Ending Capital Reserve Balance</b>	<b>\$3,459,028</b>

Minimum Capital Reserve Balance \$1,013,249

**Sewer Enterprise**

**FY 2021**

Beginning Capital Reserve Balance	\$3,065,579
Contributions for FY 2020 - 2021:	\$427,597
Planned Capital Expenditures	-\$1,076,500
<b>Ending Capital Reserve Balance</b>	<b>\$2,416,676</b>

Minimum Capital Reserve Balance \$1,048,640

# Capital Improvement Program

## WATER LINE EVALUATION IN EASEMENTS

- CI 101 -

**Description:** Evaluation of water pipe segments that run through private property easements to determine condition and potential for failure. Develop options for relocation or trenchless rehabilitation.

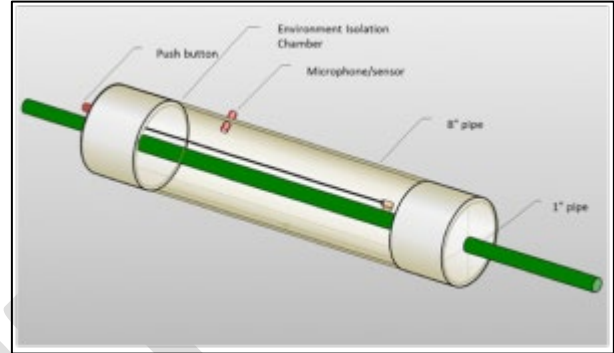

**Justification:** Water main breaks in areas where the District’s distribution system runs through private property may be costly to address repairs and damage caused if not detected early. An evaluation of the integrity of the pipeline will help determine the feasibility of slip lining these segments of pipe.

**Operations Impact:** Staff time to pothole segment to remove section for testing the structural integrity.

**Begin:** 2020  
**End:** 2021

Funding Allocation	Allocation
Water	100%
Sewer	
Solid Waste	

Project Schedule	Expended	Carryover	FY 2021	FY 2022	FY 2023	FY 2024	Total
Design							
Construction		\$20,000		\$40,000			
		\$20,000		40,000			\$60,000

# Capital Improvement Program

## WELL AMI MONITORING

- CI 102 -

**Description:** Installation of an automatic meter reading device for groundwater consumption reporting. Contingent upon District's plans to continue well operation.



**Justification:** All wells in the basin are required to be outfitted with AMI in 2020.

**Operations Impact:** N/A

**Begin:** 2019  
**End:** 2020

Funding Allocation	Allocation
Water	100%
Sewer	
Solid Waste	

Project Schedule	Expended	Carryover	FY 2020	FY 2021	FY 2022	FY 2023	FY 2024	Total
Design								
Construction		\$10,000						
		<b>\$10,000</b>						<b>\$10,000</b>

# Capital Improvement Program

## PHWA IMPROVEMENTS

- CI 103 -

**Description:** District's share of capital improvement needs at the PHWA Brackish Water Reclamation Demonstration Facility.



**Justification:** Reinvestment in the PHWA facility will be required to prolong the life of the treatment equipment. The District will be responsible for its capacity share of the improvements.

**Operations Impact:** N/A

**Begin:** 2021  
**End:** 2025

Funding Allocation	Allocation
Water	100%
Sewer	
Solid Waste	

Project Schedule	Expended	Carryover	FY 2021	FY 2022	FY 2023	FY 2024	FY 2025	Total
Design								
Construction			\$64,740	\$116,700	\$117,810	\$55,650	\$32,250	\$387,150
			<b>\$64,740</b>	<b>\$116,700</b>	<b>\$117,810</b>	<b>\$55,650</b>	<b>\$32,250</b>	<b>\$387,150</b>

# Capital Improvement Program

## WATER DISTRIBUTION IMPROVEMENTS

- CI 105 -

**Description:** Replacement of water distribution assets such as: valves, pipe segments, and other ancillary water distribution assets as needed.



**Justification:** Preparing for the need to replace water distribution assets as they fail due to age. Most valves were installed 50+ years ago.

**Operations Impact:** Increase system reliability by maximizing the operability of water system assets.

**Begin:** 2020  
**End:** 2025

Funding Allocation	Allocation
Water	100%
Sewer	
Solid Waste	

Project Schedule	Expended	Carryover	FY 2021	FY 2022	FY 2023	FY 2024	FY 2025	Total
Design								
Construction			\$50,000	\$50,000	\$50,000	\$50,000	\$50,000	
			<b>\$50,000</b>	<b>\$50,000</b>	<b>\$50,000</b>	<b>\$50,000</b>	<b>\$50,000</b>	<b>\$250,000</b>

# Capital Improvement Program

## I&I REDUCTION – GRAVITY MAIN IMPROVEMENTS & MANHOLE REHAB

- CI 201 -

**Description:** Repair and/or relining of VCP in areas where Grade IV and V defects are present. Rehabilitation of manholes. Problem areas were identified by CCTV (MI 204) per NASSCO standards.

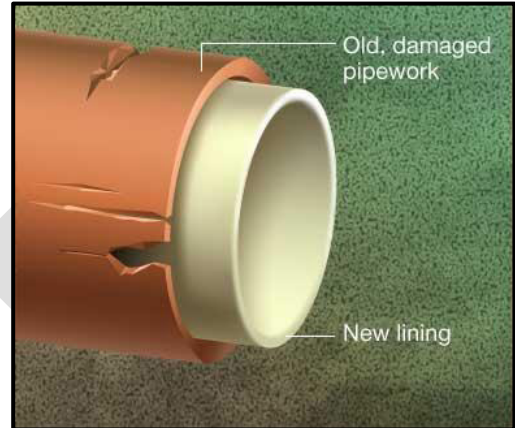

**Justification:** Repairing cracks and joints prevents unwanted infiltration, exfiltration, and reduced pumping/treatment costs.

**Operations Impact:** Potential for less pumping and treatment costs as a result of reduced infiltration flows.

**Begin:** 2019  
**End:** 2020

Funding Allocation	Allocation
Water	
Sewer	100%
Solid Waste	

Project Schedule	Expended	Carryover	FY 2020	FY 2021	FY 2022	FY 2023	FY 2024	Total
Design			\$59,309			\$30,000		
Construction				\$481,000			\$266,000	
			<b>\$59,309</b>	<b>\$481,000</b>		<b>\$30,000</b>	<b>\$266,000</b>	<b>\$836,309</b>

# Capital Improvement Program

## SEWER LIFT STATION AND PUMP STATION REHABILITATION

- CI 202 -

**Description:** Signification upgrades/rehab of the District’s seven sewer lift stations to address mechanical, electrical, safety, structural, and instrumentation needs.

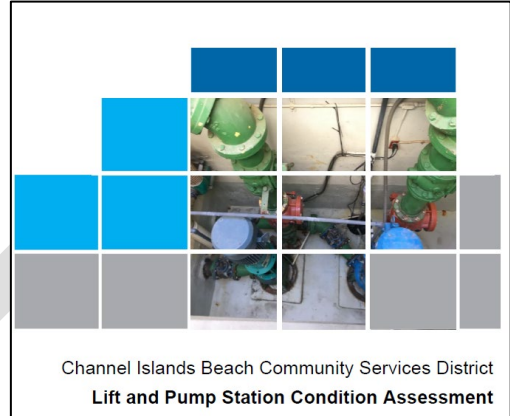

**Justification:** Project ensures the longevity and continued operation of the District’s sewer lift stations, maintains compliance with regulatory standards, and improves worker safety.

**Operations Impact:** Improvements will address operational reliability and longevity of sewer lift stations.

**Begin:** 2019  
**End:** 2024

Funding Allocation	Allocation
Water	
Sewer	100%
Solid Waste	

Project Schedule	Expended	Carryover	FY 2020	FY 2021	FY 2022	FY 2023	FY 2024	Total
Design			\$35,000		\$40,000			
Construction				\$190,000	60,000	\$320,000	100,000	
			<b>\$35,000</b>	<b>\$190,000</b>	<b>\$100,000</b>	<b>\$320,000</b>	<b>\$100,000</b>	<b>\$745,000</b>



# Capital Improvement Program

## HYDROGEN SULFIDE REDUCTION

- CI 205 -

**Description:** Treatment of wastewater flows in the collection system to reduce odor and pipe corrosion.

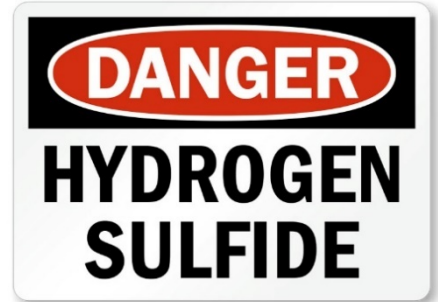

**Justification:** May be required by City of Oxnard in future (prior to discharge point into City’s collection system). Will help maintain newly relined segments of gravity lines (CI 201).

**Operations Impact:** Staff will need to maintain equipment required for chemical dosing and treatment.

**Begin:** 2021  
**End:** 2022

Funding Allocation	Allocation
Water	
Sewer	100%
Solid Waste	

Project Schedule	Expended	Carryover	FY 2020	FY 2021	FY 2022	FY 2023	FY 2024	Total
Design					\$10,000			
Construction					\$90,000			
					<b>\$100,000</b>			<b>\$100,000</b>

# Capital Improvement Program

## OXNARD WASTEWATER PLANT IMPROVEMENTS

- CI 206 -

**Description:** District's share of the necessary upgrades to the City of Oxnard's Wastewater Treatment Plant.

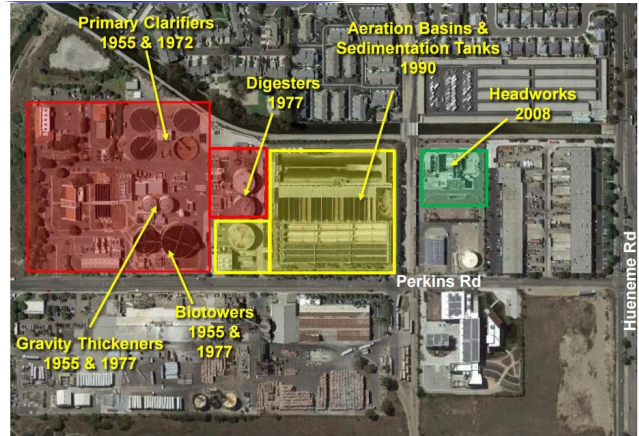

**Justification:** The District owns nearly 2% of the wastewater plant's capacity for treatment of its wastewater flows.

**Operations Impact:** N/A

**Begin:**  
**End:**

Funding Allocation	Allocation
Water	
Sewer	100%
Solid Waste	

Project Schedule	Expended	Carryover	FY 2020	FY 2021	FY 2022	FY 2023	FY 2024	Total
Design								
Construction			\$0	\$200,000	\$200,000	\$300,000	\$600,000	
			\$0	\$200,000	\$200,000	\$300,000	\$600,000	\$1,300,000

# Capital Improvement Program WASTEWATER FLOW METER INSTALLATION

- CI 208 -

**Description:** Engineering design and flow monitoring installation at sewer lift stations where necessary. Project goals are to support the mission of the 2<sup>nd</sup> Amendment to the Wastewater Transportation Agreement between District and City of Oxnard. Project will help determine actual flows and strengths generated by each agency and will assign costs accordingly.

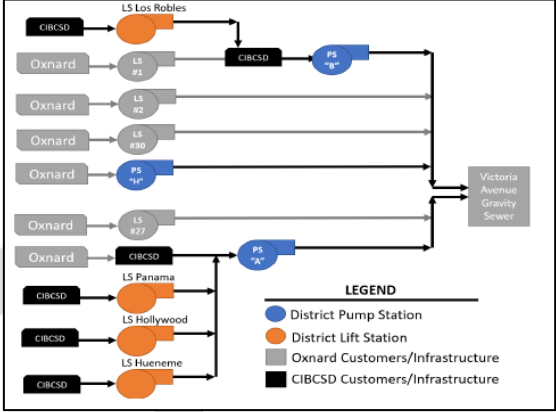

**Justification:** Helps accomplish goal of assigning wastewater conveyance and treatment costs to the appropriate agency.

**Operations Impact:**

**Begin:** 2019  
**End:** 2021

Funding Allocation	Allocation
Water	
Sewer	100%
Solid Waste	

Project Schedule	Expended	Carryover	FY 2020	FY 2021	FY 2022	FY 2023	FY 2024	Total
Design	\$19,000	\$16,000	\$40,000					
Construction				\$10,000				
	<b>\$19,000</b>	<b>\$16,000</b>	<b>\$40,000</b>	<b>\$10,000</b>				<b>\$85,000</b>

# Capital Improvement Program

## YARD & BUILDING IMPROVEMENTS

- CI 402 -

**Description:** Renovation or reconstruction of the District's main facility and yard. Project includes architectural design sessions, concept drawings, plan submittal, and construction.

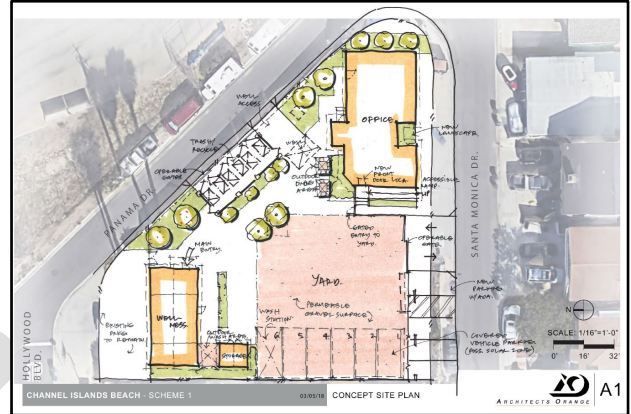

**Justification:** Project will address code and ADA Compliance issues at District's main facility.

**Operations Impact:**

**Begin:** 2019  
**End:** 2022

Funding Allocation	Allocation
Water	50%
Sewer	50%
Solid Waste	

Project Schedule	FY 2020	FY 2021	FY 2022	FY 2023	FY 2024	Total
Design	\$40,000					
Construction		\$100,000	\$1,450,000			
	<b>\$40,000</b>	<b>\$100,000</b>	<b>\$1,450,000</b>			<b>\$1,590,000</b>

# Capital Improvement Program

## ASSET MANAGEMENT SOFTWARE

- CI 403 -

**Description:** An asset management software will allow the District to better manage its capital assets by minimizing the total cost of owning, operating, and maintaining assets while improving levels of service.



**Justification:** Software will streamline workflows, schedule preventative maintenance, track historical maintenance and associated costs, and allow for more efficient asset management.

**Operations Impact:**

**Begin:** 2020  
**End:** 2021

Funding Allocation	Allocation
Water	50%
Sewer	50%
Solid Waste	

Project Schedule	FY 2021	FY 2022	FY 2023	FY 2024	Total
Design					
Construction					
	<b>\$31,000</b>				<b>\$31,000</b>

# Capital Improvement Program

## AIR COMPRESSOR UNIT REPLACEMENT

- CI 501 -

**Description:** Replacement of the District's air compressor unit that has reached the end of its useful life.



**Justification:** Air compressor used in routine maintenance activities.

**Operations Impact:**

**Begin:** 2019  
**End:** 2019

Funding Allocation	Allocation
Water	50%
Sewer	50%
Solid Waste	

Project Schedule	Expended	Carryover	FY 2020	FY 2021	FY 2022	FY 2023	FY 2024	Total
Procurement			\$12,000					\$12,000

# Capital Improvement Program

## CHANGEABLE MESSAGE SIGN

- CI 502 -

**Description:** Procurement of a changeable message sign for use during capital projects, special events, and emergency repairs.



**Justification:** Promotes public awareness and employee roadway safety.

**Operations Impact:**

**Begin:** 2019  
**End:** 2019

Funding Allocation	Allocation
Water	50%
Sewer	50%
Solid Waste	

Project Schedule	Expended	Carryover	FY 2020	FY 2021	FY 2022	FY 2023	FY 2024	Total
Procurement			\$15,000					\$15,000

# Capital Improvement Program

## CRANE TRUCK

- CI 503 -

**Description:** Replacement of a 2001 Crane Truck that has reached the end of its useful life.



**Justification:** District routinely uses its existing crane truck for both water and sewer maintenance operations. Existing crane truck was sized for water applications prior to the District owning sewer assets. New crane truck will be appropriately sized for both water and sewer functions.

**Operations Impact:**

**Begin:** 2019  
**End:** 2020

Funding Allocation	Allocation
Water	50%
Sewer	50%
Solid Waste	

Project Schedule	Expended	Carryover	FY 2020	FY 2021	FY 2022	FY 2023	FY 2024	Total
Procurement				\$150,000				\$150,000



# Capital Improvement Program

## WATER EMERGENCY RESPONSE PLAN

- MI 104 -

**Description:** A water emergency response plan summarizes disasters/emergencies that may occur in the water system’s service area, such as: earthquake, major fire emergencies, water outages due to loss of power, water contamination, and acts of sabotage.



**Justification:** Regulatory recommendation. Plan is to ensure reliable water service and minimize public health risks from unsafe drinking water during emergency events.

**Operations Impact:**

**Begin:** 2020  
**End:** 2021

Funding Allocation	Allocation
Water	100%
Sewer	
Solid Waste	

Project Schedule	Expended	Carryover	FY 2020	FY 2021	FY 2022	FY 2023	FY 2024	Total
Design				\$12,000				
Construction				\$12,000				\$12,000

# Capital Improvement Program

## WATER AND SEWER MASTER PLAN

- MI 105 -

**Description:** The most recent evaluation of District water and wastewater conveyance infrastructure was completed in February 2010 and January 2012, respectively. Due to the changes in water supply and demand since that time, age of infrastructure and need to accurately financially plan as part of the anticipated 2020-21 Rate Study, it is necessary to update these documents. The intent is to combine the updated documents into a single District Infrastructure Master Plan.



**Justification:**

1. 5-year CIP budget for incorporation in the Rate Study process
2. Updated hydraulic models for use in Development Reviews
3. Evaluation of future water supply options, including participation with PHWA and others
4. Deliver updated demand projections for incorporation in the 2020 PHWA Urban Water Management Plan
5. Assists in employee knowledge transfer and future planning

**Begin:** 2020  
**End:** 2021

Funding Allocation	Allocation
Water	50%
Sewer	50%
Solid Waste	

Project Schedule	FY 2021	FY 2022	FY 2023	FY 2024	Total
Design	\$75,000				
Construction					
	<b>\$75,000</b>				<b>\$75,000</b>

# Capital Improvement Program

**CCTV VIDEO INSPECTION PROGRAM**  
- MI 204 -

**Description:** Cleaning and videoing of the District gravity sewer collection system.

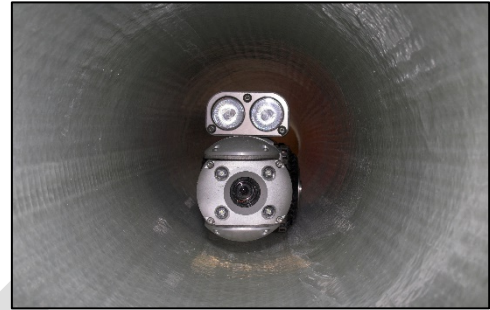

**Justification:** Results from the CCTV video will inform District of vulnerable areas in the sewer collection system that require repair or additional maintenance.

**Operations Impact:** N/A

**Begin:** 2024  
**End:** 2024

Funding Allocation	Allocation
Water	
Sewer	100%
Solid Waste	

Project Schedule	Expended	Carryover	FY 2020	FY 2021	FY 2022	FY 2023	FY 2024	Total
Design								
Construction							\$85,000	
							<b>\$85,000</b>	<b>\$85,000</b>

# Capital Improvement Program

## SEWER SYSTEM MANAGEMENT PLAN

- MI 209 -

**Description:** The SSMP is a document that describes the activities the District uses to manage the wastewater collection system effectively. The elements include maintenance operations, minimizing I&I, and minimizing/addressing SSOs that may occur. SSMP was last adopted in 2009.



**Justification:** All public agencies that own or operate sanitary sewer systems greater than one mile in length that collect and/or convey wastewater to publicly owned treatment facilities are required to have a current Sewer System Management Plan (SSMP).

**Operations Impact:**

**Begin:** 2019  
**End:** 2020

Funding Allocation	Allocation
Water	
Sewer	100%
Solid Waste	

Project Schedule	Expended	Carryover	FY 2020	FY 2021	FY 2022	FY 2023	FY 2024	Total
Design			\$12,000					
Construction								
			\$12,000					\$12,000

# Capital Improvement Program

## WATER & SEWER RATE STUDY

- MI 404 -

**Description:** Update to the District's 2016 Combination Water & Sewer Rate Study. Future Board direction will determine if scope will contain Financial Plan and/or Cost of Service Study.

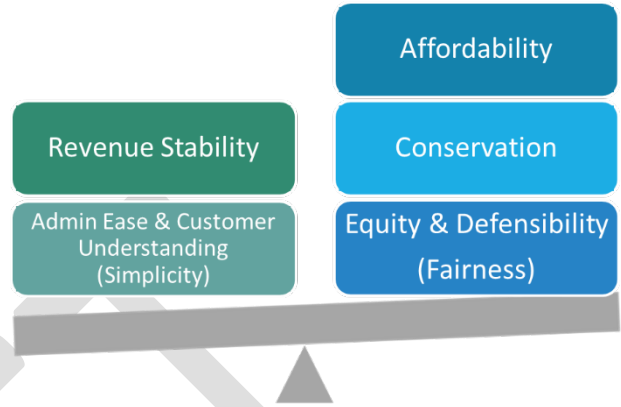

**Justification:** The District's 5-year rate plan will end in July 2021. A cost of service study is required every 10 years, but is often completed every 5 years. Staff will make a recommendation on whether a cost of service study is necessary as part of the next rate study.

**Operations Impact:**

**Begin:** 2020  
**End:** 2021

Funding Allocation	Allocation
Water	50%
Sewer	50%
Solid Waste	

Project Schedule	Expended	Carryover	FY 2020	FY 2021	FY 2022	FY 2023	FY 2024	Total
Design			\$5,000	\$35,000				
Construction			\$5,000	\$35,000				\$40,000